



US009735378B2

(12) **United States Patent**  
**Xia et al.**

(10) **Patent No.:** **US 9,735,378 B2**  
(45) **Date of Patent:** **Aug. 15, 2017**

(54) **ORGANIC ELECTROLUMINESCENT MATERIALS AND DEVICES**

5,247,190 A 9/1993 Friend et al.  
5,703,436 A 12/1997 Forrest et al.  
5,707,745 A 1/1998 Forrest et al.  
5,834,893 A 11/1998 Bulovic et al.  
5,844,363 A 12/1998 Gu et al.  
6,013,982 A 1/2000 Thompson et al.  
6,087,196 A 7/2000 Sturm et al.  
6,091,195 A 7/2000 Forrest et al.

(71) Applicant: **Universal Display Corporation**,  
Ewing, NJ (US)

(72) Inventors: **Chuanjun Xia**, Lawrenceville, NJ  
(US); **Chun Lin**, Yardley, PA (US)

(73) Assignee: **UNIVERSAL DISPLAY CORPORATION**, Ewing, NJ (US)

FOREIGN PATENT DOCUMENTS

(\* ) Notice: Subject to any disclaimer, the term of this patent is extended or adjusted under 35 U.S.C. 154(b) by 918 days.

EP 0650955 5/1995  
EP 1725079 11/2006

(Continued)

(21) Appl. No.: **14/021,274**

OTHER PUBLICATIONS

(22) Filed: **Sep. 9, 2013**

(65) **Prior Publication Data**

US 2015/0069334 A1 Mar. 12, 2015

Tsuboyama, Akira, et al., "A novel dinuclear cyclometalated iridium complex bridged with 1,4-bis[pyridine-2-yl] benzene: its structure and photophysical properties," The Royal Society of Chemistry, Mar. 2004, Dalton Trans., 2004, pp. 1115-1116.

(Continued)

(51) **Int. Cl.**

**H01L 51/00** (2006.01)  
**C07F 15/00** (2006.01)  
**C09K 11/06** (2006.01)  
**H01L 51/50** (2006.01)

Primary Examiner — Robert Vetere

(74) Attorney, Agent, or Firm — Duane Morris LLP

(52) **U.S. Cl.**

CPC ..... **H01L 51/009** (2013.01); **C07F 15/0033** (2013.01); **C07F 15/0086** (2013.01); **C09K 11/06** (2013.01); **C09K 2211/185** (2013.01); **H01L 51/0087** (2013.01); **H01L 51/5016** (2013.01)

(57) **ABSTRACT**

Ir/Pt metal complexes, devices containing the Ir/Pt metal complexes, and methods of making such devices are described. The Ir/Pt metal complex includes a first Ir moiety and a first Pt moiety. The first Ir moiety can be an Ir(III) six-coordinated structure. The first Pt moiety can be a Pt(II) four-coordinated tetradentate structure. The devices can have layers that include the Ir/Pt metal complexes. The layers containing the Ir/Pt metal complexes can be made by a solution process.

(58) **Field of Classification Search**

CPC ..... H01L 51/009  
See application file for complete search history.

(56) **References Cited**

U.S. PATENT DOCUMENTS

4,769,292 A 9/1988 Tang et al.  
5,061,569 A 10/1991 VanSlyke et al.

**43 Claims, 5 Drawing Sheets**

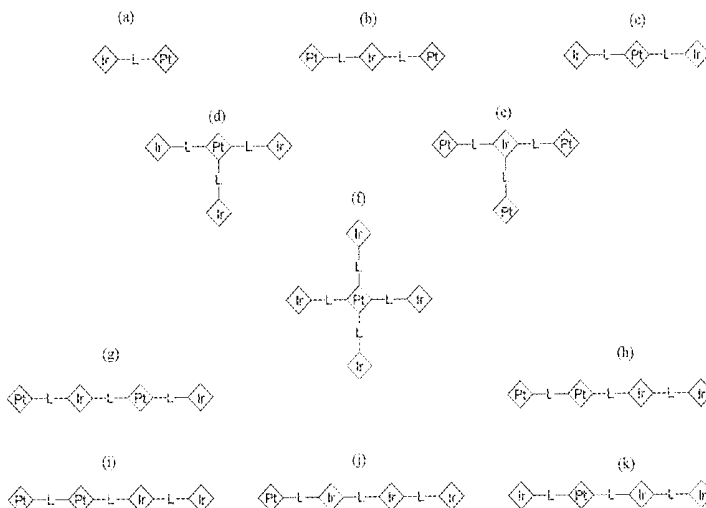

(56)

## References Cited

U.S. PATENT DOCUMENTS

6,097,147 A 8/2000 Baldo et al.  
 6,288,229 B1 9/2001 Komatsuzaki et al.  
 6,294,398 B1 9/2001 Kim et al.  
 6,303,238 B1 10/2001 Thompson et al.  
 6,337,102 B1 1/2002 Forrest et al.  
 6,468,819 B1 10/2002 Kim et al.  
 6,528,187 B1 3/2003 Okada  
 6,687,266 B1 2/2004 Ma et al.  
 6,835,469 B2 12/2004 Kwong et al.  
 6,921,915 B2 7/2005 Takiguchi et al.  
 7,087,321 B2 8/2006 Kwong et al.  
 7,090,928 B2 8/2006 Thompson et al.  
 7,154,114 B2 12/2006 Brooks et al.  
 7,250,226 B2 7/2007 Tokito et al.  
 7,279,704 B2 10/2007 Walters et al.  
 7,332,232 B2 2/2008 Ma et al.  
 7,338,722 B2 3/2008 Thompson et al.  
 7,393,599 B2 7/2008 Thompson et al.  
 7,396,598 B2 7/2008 Takeuchi et al.  
 7,431,968 B1 10/2008 Shtein et al.  
 7,445,855 B2 11/2008 MacKenzie et al.  
 7,534,505 B2 5/2009 Lin et al.  
 2002/0034656 A1 3/2002 Thompson et al.  
 2002/0134984 A1 9/2002 Igarashi  
 2002/0158242 A1 10/2002 Son et al.  
 2003/0138657 A1 7/2003 Li et al.  
 2003/0152802 A1\* 8/2003 Tsuboyama ..... C07F 15/0033  
 428/690  
 2003/0162053 A1 8/2003 Marks et al.  
 2003/0175553 A1 9/2003 Thompson et al.  
 2003/0230980 A1 12/2003 Forrest et al.  
 2004/0036077 A1 2/2004 Ise  
 2004/0137267 A1 7/2004 Igarashi et al.  
 2004/0137268 A1 7/2004 Igarashi et al.  
 2004/0174116 A1 9/2004 Lu et al.  
 2004/0197600 A1 10/2004 Thompson et al.  
 2005/0025993 A1 2/2005 Thompson et al.  
 2005/0112407 A1 5/2005 Ogasawara et al.  
 2005/0238919 A1 10/2005 Ogasawara  
 2005/0244673 A1 11/2005 Satoh et al.  
 2005/0260441 A1\* 11/2005 Thompson ..... C07F 15/0033  
 428/690  
 2005/0260449 A1 11/2005 Walters et al.  
 2006/0008670 A1 1/2006 Lin et al.  
 2006/0202194 A1 9/2006 Jeong et al.  
 2006/0240279 A1 10/2006 Adamovich et al.  
 2006/0251923 A1 11/2006 Lin et al.  
 2006/0263632 A1 11/2006 Igarashi et al.  
 2006/0263635 A1 11/2006 Ise  
 2006/0280965 A1 12/2006 Kwong et al.  
 2007/0190359 A1 8/2007 Knowles et al.  
 2007/0267959 A1 11/2007 Ragini et al.  
 2007/0278938 A1 12/2007 Yabunouchi et al.  
 2008/0015355 A1 1/2008 Schafer et al.  
 2008/0018221 A1 1/2008 Egen et al.  
 2008/0106190 A1 5/2008 Yabunouchi et al.  
 2008/0124572 A1 5/2008 Mizuki et al.  
 2008/0220265 A1 9/2008 Xia et al.  
 2008/0297033 A1 12/2008 Knowles et al.  
 2009/0008605 A1 1/2009 Kawamura et al.  
 2009/0009065 A1 1/2009 Nishimura et al.  
 2009/0017330 A1 1/2009 Iwakuma et al.  
 2009/0030202 A1 1/2009 Iwakuma et al.  
 2009/0039776 A1 2/2009 Yamada et al.  
 2009/0045730 A1 2/2009 Nishimura et al.  
 2009/0045731 A1 2/2009 Nishimura et al.  
 2009/0058279 A1\* 3/2009 Takeda ..... C09K 11/06  
 313/504  
 2009/0101870 A1 4/2009 Prakash et al.  
 2009/0108737 A1 4/2009 Kwong et al.  
 2009/0115316 A1 5/2009 Zheng et al.  
 2009/0165846 A1 7/2009 Johannes et al.  
 2009/0167162 A1 7/2009 Lin et al.  
 2009/0179554 A1 7/2009 Kuma et al.

2010/0237334 A1\* 9/2010 Ma ..... C07D 307/91  
 257/40

2011/0187265 A1 8/2011 De Cola et al.  
 2011/0198573 A1\* 8/2011 Iida ..... C08G 61/12  
 257/40

## FOREIGN PATENT DOCUMENTS

EP 2034538 3/2009  
 JP 200511610 1/2005  
 JP 2007123392 5/2007  
 JP 2007254297 10/2007  
 JP 2008074939 4/2008  
 KR 20100084095 7/2010  
 WO 0139234 5/2001  
 WO 0202714 1/2002  
 WO 0215645 2/2002  
 WO 03040257 5/2003  
 WO 03060956 7/2003  
 WO 2004093207 10/2004  
 WO 2004107822 12/2004  
 WO 2005014551 2/2005  
 WO 2005019373 3/2005  
 WO 2005030900 4/2005  
 WO 2005089025 9/2005  
 WO 2005123873 12/2005  
 WO 2006009024 1/2006  
 WO 2006056418 6/2006  
 WO 2006072002 7/2006  
 WO 2006082742 8/2006  
 WO 2006098120 9/2006  
 WO 2006100298 9/2006  
 WO 2006103874 10/2006  
 WO 2006114966 11/2006  
 WO 2006132173 12/2006  
 WO 2007002683 1/2007  
 WO 2007004380 1/2007  
 WO 2007063754 6/2007  
 WO 2007063796 6/2007  
 WO 2008056746 5/2008  
 WO 2008101842 8/2008  
 WO 2008132085 11/2008  
 WO 2009000673 12/2008  
 WO 2009003898 1/2009  
 WO 2009008311 1/2009  
 WO 2009018009 2/2009  
 WO 2009050290 4/2009  
 WO 2009021126 5/2009  
 WO 2009062578 5/2009  
 WO 2009063833 5/2009  
 WO 2009066778 5/2009  
 WO 2009066779 5/2009  
 WO 2009086028 7/2009  
 WO 2009100991 8/2009

## OTHER PUBLICATIONS

McCusker, Catherine, et al., "Metal Coordination Induced  $\pi$ -Extension and Triplet State Production in Diketopyrrolopyrrole Chromophores," *Inorganic Chemistry*, 2012, vol. 51, pp. 7957-7959.

Bronner, Catherine, et al., "Excited State Properties and Energy Transfer within Dipyrrin-Based Binuclear Iridium/Platinum Dyads: The Effect of ortho-Methylation on the Spacer," *Chemistry—A European Journal*, Mar. 26, 2012, vol. 18, No. 13, pp. 4041-4050.

Adachi, Chihaya et al., "Organic Electroluminescent Device Having a Hole Conductor as an Emitting Layer," *Appl. Phys. Lett.*, 55(15): 1489-1491 (1989).

Adachi, Chihaya et al., "Nearly 100% Internal Phosphorescence Efficiency in an Organic Light Emitting Device," *J. Appl. Phys.*, 90(10): 5048-5051 (2001).

Adachi, Chihaya et al., "High-Efficiency Red Electrophosphorescence Devices," *Appl. Phys. Lett.*, 78(11):1622-1624 (2001).

Aonuma, Masaki et al., "Material Design of Hole Transport Materials Capable of Thick-Film Formation in Organic Light Emitting Diodes," *Appl. Phys. Lett.*, 90:183503-1-183503-3.

(56)

## References Cited

## OTHER PUBLICATIONS

- Baldo et al., "Highly Efficient Phosphorescent Emission from Organic Electroluminescent Devices," *Nature*, vol. 395, 151-154, (1998).
- Baldo et al., "Very high-efficiency green organic light-emitting devices based on electrophosphorescence," *Appl. Phys. Lett.*, vol. 75, No. 3, 4-6 (1999).
- Gao, Zhiqiang et al., "Bright-Blue Electroluminescence From a Silyl-Substituted ter-(phenylene-vinylene) derivative," *Appl. Phys. Lett.*, 74(6): 865-867 (1999).
- Guo, Tzung-Fang et al., "Highly Efficient Electrophosphorescent Polymer Light-Emitting Devices," *Organic Electronics*, 115-20 (2000).
- Hamada, Yuji et al., "High Luminance in Organic Electroluminescent Devices with Bis(10-hydroxybenzo[h]quinolino) beryllium as an Emitter," *Chem. Lett.*, 905-906 (1993).
- Holmes, R.J. et al., "Blue Organic Electrophosphorescence Using Exothermic Host-Guest Energy Transfer," *Appl. Phys. Lett.*, 82(15):2422-2424 (2003).
- Hu, Nan-Xing et al., "Novel High Tg Hole-Transport Molecules Based on Indolo[3,2-b]carbazoles for Organic Light-Emitting Devices," *Synthetic Metals*, 111-112:421-424 (2000).
- Huang, Jinsong et al., "Highly Efficient Red-Emission Polymer Phosphorescent Light-Emitting Diodes Based on Two Novel Tris(1-phenylisoquinolino-C2,N)iridium(III) Derivates," *Adv. Mater.*, 19:739-743 (2007).
- Huang, Wei-Sheng et al., "Highly Phosphorescent Bis-Cyclometalated Iridium Complexes Containing Benzoimidazole-Based Ligands," *Chem. Mater.*, 16(12):2480-2488 (2004).
- Hung, L.S. et al., "Anode Modification in Organic Light-Emitting Diodes by Low-Frequency Plasma Polymerization of CHF<sub>3</sub>," *Appl. Phys. Lett.*, 78(5):673-675 (2001).
- Ikai, Masamichi and Tokito, Shizuo, "Highly Efficient Phosphorescence From Organic Light-Emitting Devices with an Exciton-Block Layer," *Appl. Phys. Lett.*, 79(2):156-158 (2001).
- Ikeda, Hisao et al., "P-185 Low-Drive-Voltage OLEDs with a Buffer Layer Having Molybdenum Oxide," *SID Symposium Digest*, 37:923-926 (2006).
- Inada, Hiroshi and Shirota, Yasuhiko, "1,3,5-Tris[4-(diphenylamino)phenyl]benzene and its Methylsubstituted Derivatives as a Novel Class of Amorphous Molecular Materials," *J. Mater. Chem.*, 3(3) 319-320 (1993).
- Kanno, Hiroshi et al., "Highly Efficient and Stable Red Phosphorescent Organic Light-Emitting Device Using bis[2-(2-benzothiazoyl)phenolato]zinc(II) as host material," *Appl. Phys. Lett.*, 90:123509-1-123509-3 (2007).
- Kido, Junji et al., 1,2,4-Triazole Derivative as an Electron Transport Layer in Organic Electroluminescent Devices, *Jpn. J. Appl. Phys.*, 32:L917-L920 (1993).
- Kuwabara, Yoshiyuki et al., "Thermally Stable Multilayered Organic Electroluminescent Devices Using Novel Starburst Molecules, 4,4',4''-Tri(N-carbazoyl)triphenylamine (TCTA) and 4,4',4''-Tris(3-methylphenylphenyl-amino) triphenylamine (m-MTDATA), as Hole-Transport Materials," *Adv. Mater.*, 6(9):677-679 (1994).
- Kwong, Raymond C. et al., "High Operational Stability of Electrophosphorescent Devices," *Appl. Phys. Lett.*, 81(1) 162-164 (2002).
- Lamansky, Sergey et al., "Synthesis and Characterization of Phosphorescent Cyclometalated Iridium Complexes," *Inorg. Chem.*, 40(7):1704-1711 (2001).
- Lee, Chang-Lyoul et al., "Polymer Phosphorescent Light-Emitting Devices with Tris(2-phenylpyridine) Iridium as a Triplet Emitter," *Appl. Phys. Lett.*, 77(15):2280-2282 (2000).
- Lo, Shih-Chun et al., "Blue Phosphorescence from Iridium(III) Complexes at Room Temperature," *Chem. Mater.*, 18 (21)5119-5129 (2006).
- Ma, Yuguang et al., "Triplet Luminescent Dinuclear-Gold(I) Complex-Based Light-Emitting Diodes with Low Turn-On voltage," *Appl. Phys. Lett.*, 74(10):1361-1363 (1999).
- Mi, Biao-Xiu et al., "Thermally Stable Hole-Transporting Material for Organic Light-Emitting Diode an Isoindole Derivative," *Chem. Mater.*, 15(16):3148-3151 (2003).
- Nishida, Jun-ichi et al., "Preparation, Characterization, and Electroluminescence Characteristics of  $\alpha$ -Diimine-type Platinum(II) Complexes with Perfluorinated Phenyl Groups as Ligands," *Chem. Lett.*, 34(4) 592-593 (2005).
- Niu, Yu-Hua et al., "Highly Efficient Electrophosphorescent Devices with Saturated Red Emission from a Neutral Osmium Complex," *Chem. Mater.*, 17(13):3532-3536 (2005).
- Noda, Tetsuya and Shirota, Yasuhiko, "5,5'-Bis(dimethylboryl)-2,2'-bithiophene and 5,5'-Bis(dimethylboryl)-2,2',5',2''-terthiophene as a Novel Family of Electron-Transporting Amorphous Molecular Materials," *J. Am. Chem. Soc.*, 120 (37):9714-9715 (1998).
- Okumoto, Kenji et al., "Green Fluorescent Organic Light-Emitting Device with External Quantum Efficiency of Nearly 10%," *Appl. Phys. Lett.*, 89:063504-1-063504-3 (2006).
- Palilis, Leonidas C., "High Efficiency Molecular Organic Light-Emitting Diodes Based on Silole Derivatives and Their Exciplexes," *Organic Electronics*, 4:113-121 (2003).
- Paulose, Betty Marie Jennifer S. et al., "First Examples of Alkenyl Pyridines as Organic Ligands for Phosphorescent Iridium Complexes," *Adv. Mater.*, 16(22) 2003-2007 (2004).
- Ranjan, Sudhir et al., "Realizing Green Phosphorescent Light-Emitting Materials from Rhenium(I) Pyrazolato Diimine Complexes," *Inorg. Chem.*, 42(4): 1248-1255 (2003).
- Sakamoto, Youichi et al., "Synthesis, Characterization, and Electron-Transport Property of Perfluorinated Phenylene Dendrimers," *J. Am. Chem. Soc.*, 122(8): 1832-1833 (2000).
- Salbeck, J. et al., "Low Molecular Organic Glasses for Blue Electroluminescence," *Synthetic Metals*, 91209-215 (1997).
- Shirota, Yasuhiko et al., "Starburst Molecules Based on p-Electron Systems as Materials for Organic Electroluminescent Devices," *Journal of Luminescence*, 72-74:985-991 (1997).
- Sotoyama, Wataru et al., "Efficient Organic Light-Emitting Diodes with Phosphorescent Platinum Complexes Containing N<sup>A</sup>C<sup>A</sup>N- Coordinating Tridentate Ligand," *Appl. Phys. Lett.*, 86: 153505-1-153505-3 (2005).
- Sun, Yiru and Forrest, Stephen R., "High-Efficiency White Organic Emitting Devices with Three Separate Phosphorescent Emission Layers," *Appl. Phys. Lett.*, 91:263503-1-263503-3 (2007).
- T. Östergård et al., "Langmuir-Blodgett Light-Emitting Diodes of Poly(3-Hexylthiophene) Electro-Optical Characteristics Related to Structure," *Synthetic Metals*, 87:171-177 (1997).
- Takizawa, Shin-ya et al., "Phosphorescent Iridium Complexes Based on 2-Phenylimidazo[1,2- $\alpha$ ]pyridine Ligands Tuning of Emission Color toward the Blue Region and Application to Polymer Light-Emitting Devices," *Inorg. Chem.*, 46(10):4308-4319 (2007).
- Tang, C.W. and VanSlyke, S.A., "Organic Electroluminescent Diodes," *Appl. Phys. Lett.*, 51(12):913-915 (1987).
- Tung, Yung-Liang et al., "Organic Light-Emitting Diodes Based on Charge-Neutral Ru II Phosphorescent Emitters," *Adv. Mater.*, 17(8):1059-1064 (2005).
- Van Slyke, S. A. et al., "Organic Electroluminescent Devices with Improved Stability," *Appl. Phys. Lett.*, 69 (15):2160-2162 (1996).
- Wang, Y. et al., "Highly Efficient Electroluminescent Materials Based on Fluorinated Organometallic Iridium Compounds," *Appl. Phys. Lett.*, 79(4) 449-451 (2001).
- Wong, Keith Man-Chung et al., A Novel Class of Phosphorescent Gold(III) Alkynyl-Based Organic Light-Emitting Devices with Tunable Colour, *Chem. Commun.*, 2906-2908 (2005).
- Wong, Wai-Yeung, "Multifunctional Iridium Complexes Based on Carbazole Modules as Highly Efficient Electrophosphors," *Angew. Chem. Int. Ed.*, 45 7800-7803 (2006).

\* cited by examiner

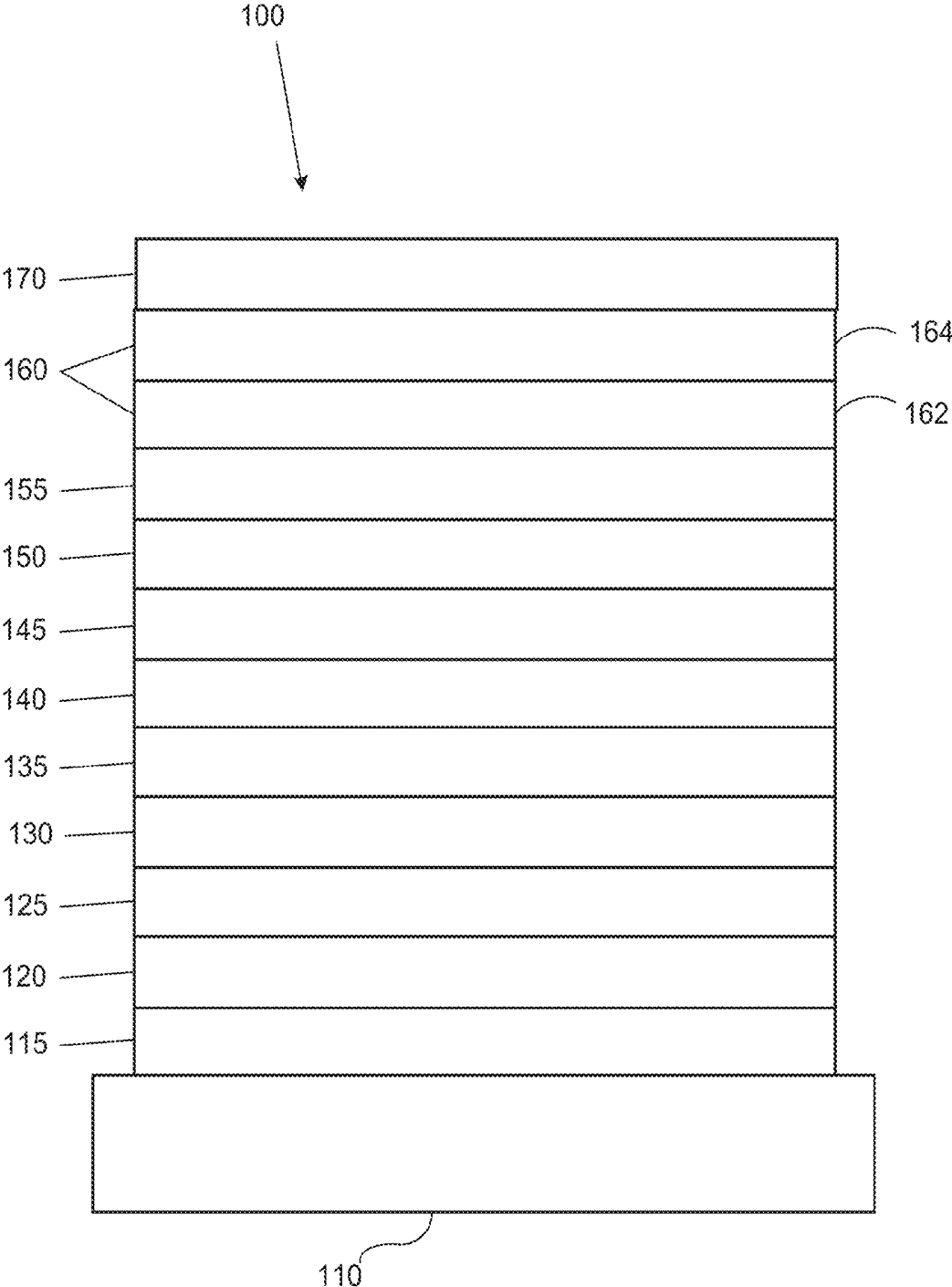

FIGURE 1

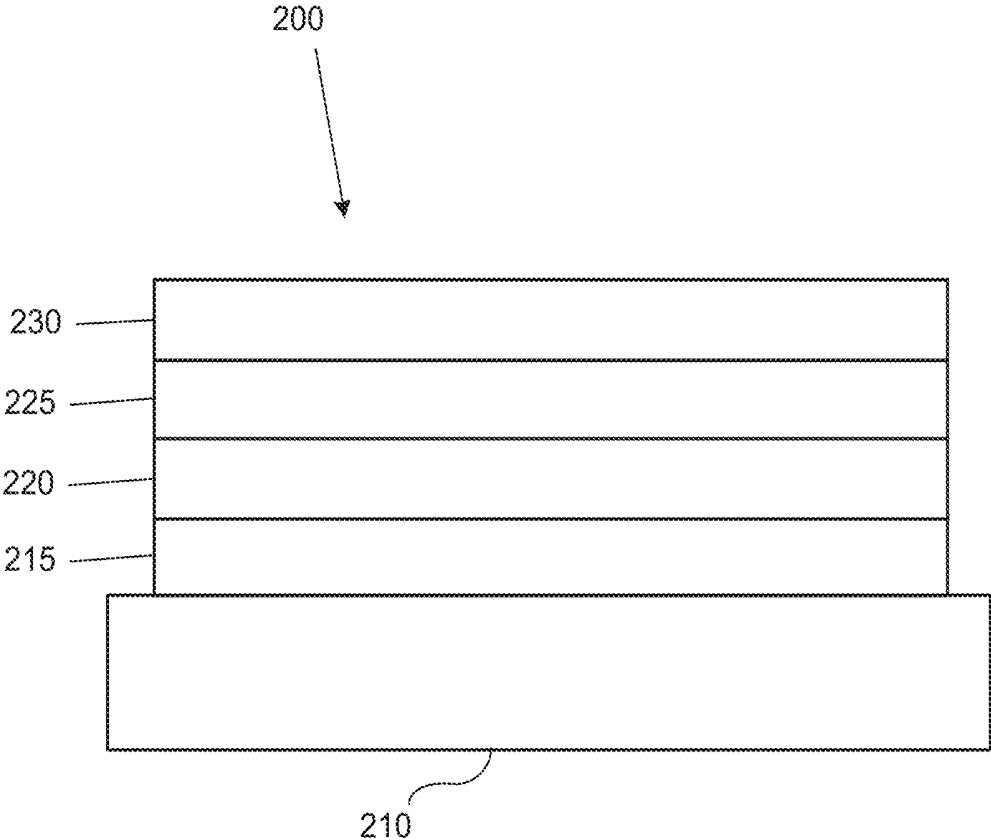

FIGURE 2

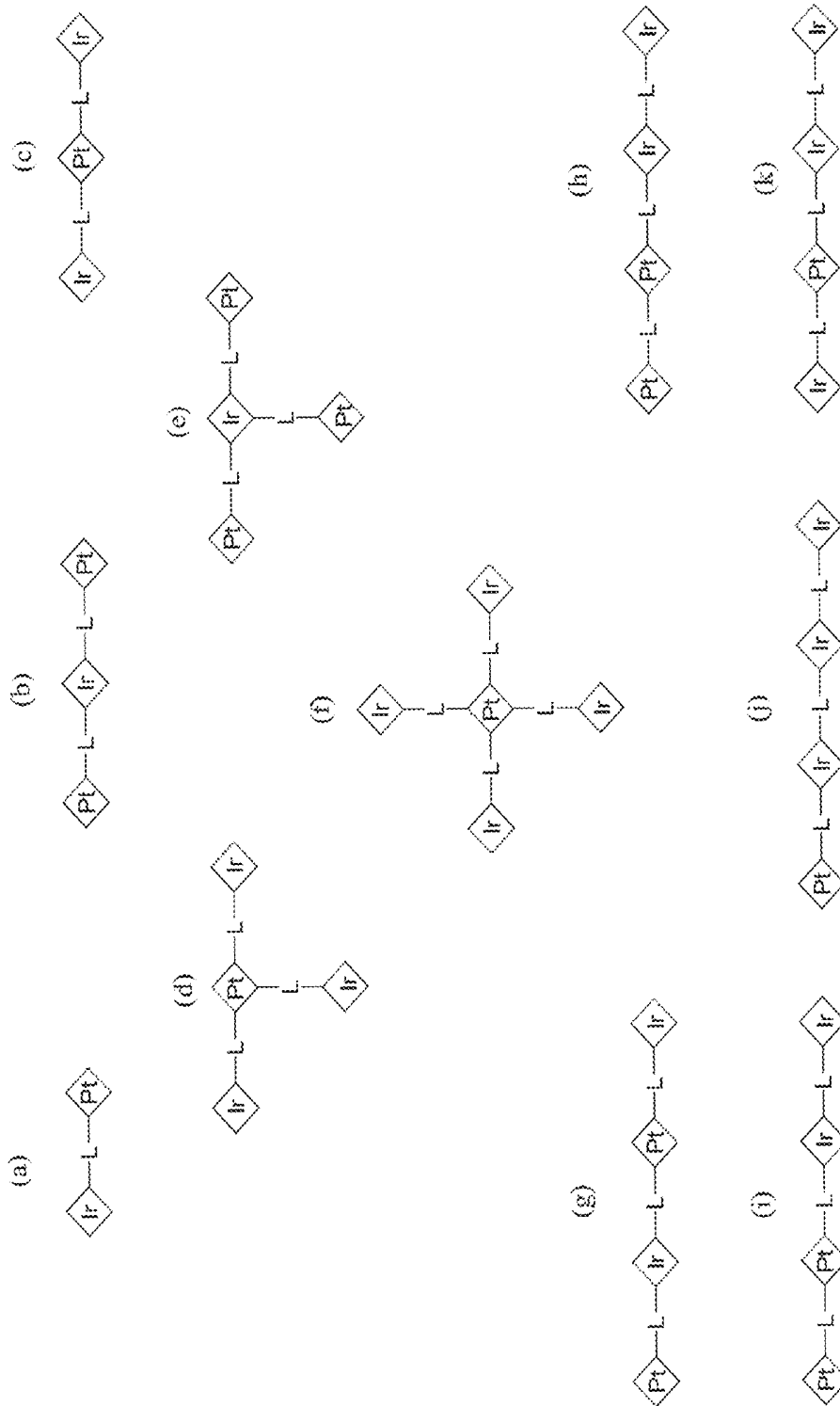

FIGURE 3

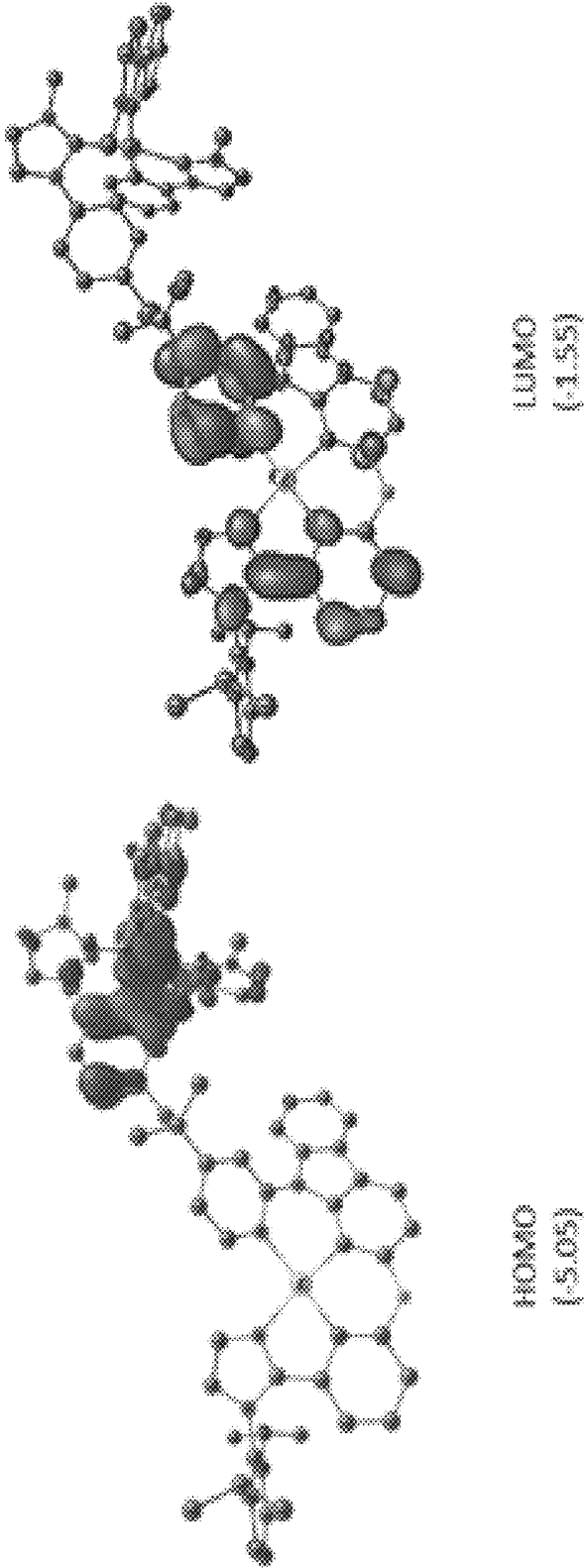

FIG. 4

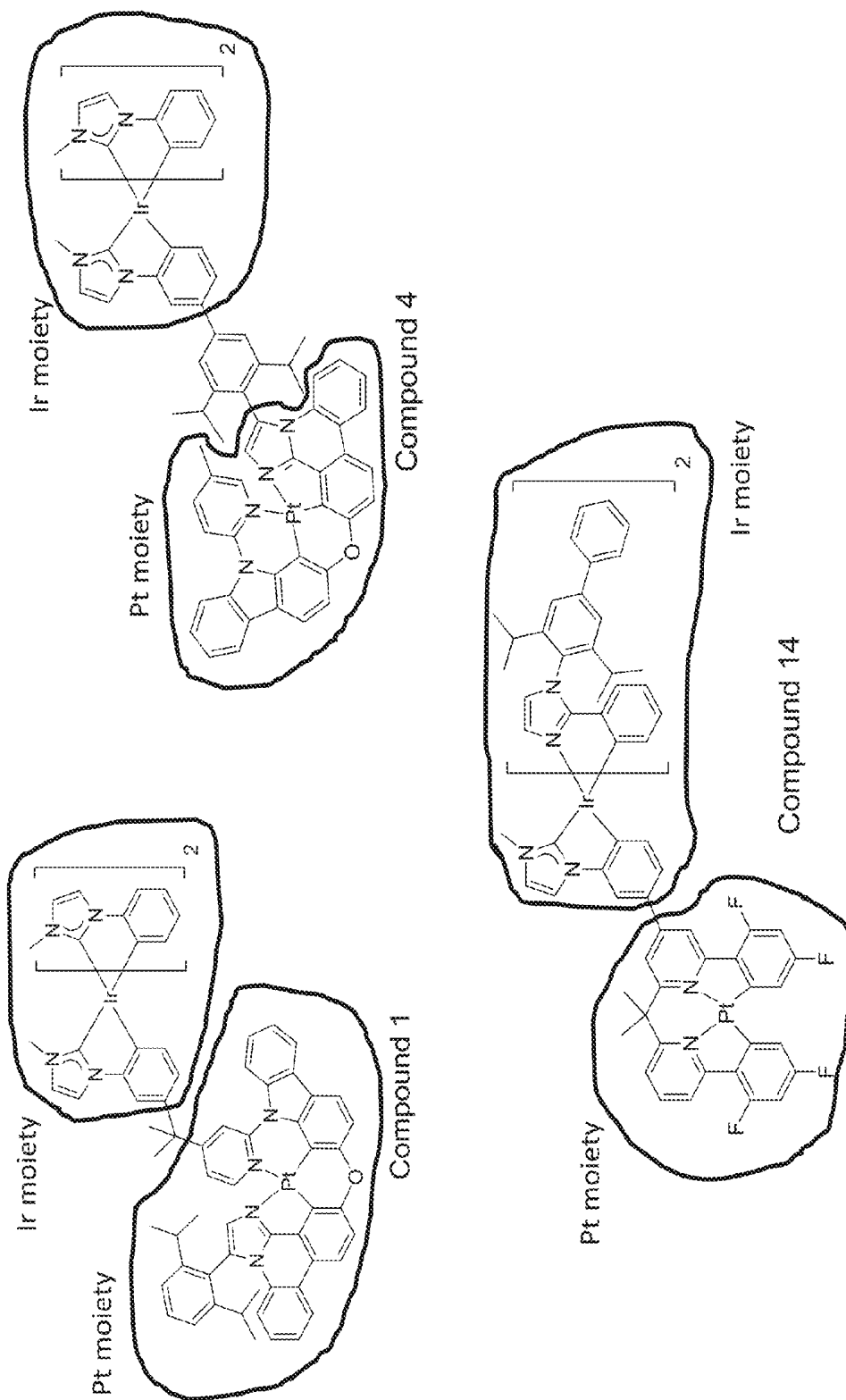

FIG. 5

1

## ORGANIC ELECTROLUMINESCENT MATERIALS AND DEVICES

### PARTIES TO A JOINT RESEARCH AGREEMENT

The claimed invention was made by, on behalf of, and/or in connection with one or more of the following parties to a joint university corporation research agreement: Regents of the University of Michigan, Princeton University, University of Southern California, and the Universal Display Corporation. The agreement was in effect on and before the date the claimed invention was made, and the claimed invention was made as a result of activities undertaken within the scope of the agreement.

### FIELD OF THE INVENTION

The present invention relates to compounds for use as emitters and devices, such as organic light emitting diodes, including the same.

### BACKGROUND

Opto-electronic devices that make use of organic materials are becoming increasingly desirable for a number of reasons. Many of the materials used to make such devices are relatively inexpensive, so organic opto-electronic devices have the potential for cost advantages over inorganic devices. In addition, the inherent properties of organic materials, such as their flexibility, may make them well suited for particular applications such as fabrication on a flexible substrate. Examples of organic opto-electronic devices include organic light emitting devices (OLEDs), organic phototransistors, organic photovoltaic cells, and organic photodetectors. For OLEDs, the organic materials may have performance advantages over conventional materials. For example, the wavelength at which an organic emissive layer emits light may generally be readily tuned with appropriate dopants.

OLEDs make use of thin organic films that emit light when voltage is applied across the device. OLEDs are becoming an increasingly interesting technology for use in applications such as flat panel displays, illumination, and backlighting. Several OLED materials and configurations are described in U.S. Pat. Nos. 5,844,363, 6,303,238, and 5,707,745, which are incorporated herein by reference in their entirety.

One application for phosphorescent emissive molecules is a full color display. Industry standards for such a display call for pixels adapted to emit particular colors, referred to as "saturated" colors. In particular, these standards call for saturated red, green, and blue pixels. Color may be measured using CIE coordinates, which are well known to the art.

One example of a green emissive molecule is tris(2-phenylpyridine)iridium, denoted Ir(ppy)<sub>3</sub>, which has the following structure:

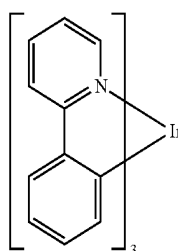

2

In this, and later figures herein, we depict the dative bond from nitrogen to metal (here, Ir) as a straight line.

As used herein, the term "organic" includes polymeric materials as well as small molecule organic materials that may be used to fabricate organic opto-electronic devices. "Small molecule" refers to any organic material that is not a polymer, and "small molecules" may actually be quite large. Small molecules may include repeat units in some circumstances. For example, using a long chain alkyl group as a substituent does not remove a molecule from the "small molecule" class. Small molecules may also be incorporated into polymers, for example as a pendent group on a polymer backbone or as a part of the backbone. Small molecules may also serve as the core moiety of a dendrimer, which consists of a series of chemical shells built on the core moiety. The core moiety of a dendrimer may be a fluorescent or phosphorescent small molecule emitter. A dendrimer may be a "small molecule," and it is believed that all dendrimers currently used in the field of OLEDs are small molecules.

As used herein, "top" means furthest away from the substrate, while "bottom" means closest to the substrate. Where a first layer is described as "disposed over" a second layer, the first layer is disposed further away from substrate. There may be other layers between the first and second layer, unless it is specified that the first layer is "in contact with" the second layer. For example, a cathode may be described as "disposed over" an anode, even though there are various organic layers in between.

As used herein, "solution processible" means capable of being dissolved, dispersed, or transported in and/or deposited from a liquid medium, either in solution or suspension form.

A ligand may be referred to as "photoactive" when it is believed that the ligand directly contributes to the photoactive properties of an emissive material. A ligand may be referred to as "ancillary" when it is believed that the ligand does not contribute to the photoactive properties of an emissive material, although an ancillary ligand may alter the properties of a photoactive ligand.

As used herein, and as would be generally understood by one skilled in the art, a first "Highest Occupied Molecular Orbital" (HOMO) or "Lowest Unoccupied Molecular Orbital" (LUMO) energy level is "greater than" or "higher than" a second HOMO or LUMO energy level if the first energy level is closer to the vacuum energy level. Since ionization potentials (IP) are measured as a negative energy relative to a vacuum level, a higher HOMO energy level corresponds to an IP having a smaller absolute value (an IP that is less negative). Similarly, a higher LUMO energy level corresponds to an electron affinity (EA) having a smaller absolute value (an EA that is less negative). On a conventional energy level diagram, with the vacuum level at the top, the LUMO energy level of a material is higher than the HOMO energy level of the same material. A "higher" HOMO or LUMO energy level appears closer to the top of such a diagram than a "lower" HOMO or LUMO energy level.

As used herein, and as would be generally understood by one skilled in the art, a first work function is "greater than" or "higher than" a second work function if the first work function has a higher absolute value. Because work functions are generally measured as negative numbers relative to vacuum level, this means that a "higher" work function is more negative. On a conventional energy level diagram, with the vacuum level at the top, a "higher" work function is illustrated as further away from the vacuum level in the

downward direction. Thus, the definitions of HOMO and LUMO energy levels follow a different convention than work functions.

More details on OLEDs, and the definitions described above, can be found in U.S. Pat. No. 7,279,704, which is incorporated herein by reference in its entirety.

#### SUMMARY OF THE INVENTION

According to an embodiment, a compound is provided that includes a first Ir moiety and a first Pt moiety. The first Ir moiety is an Ir(III) six-coordinated structure, and the first Pt moiety is a Pt(II) four-coordinated structure. The first Pt moiety includes a tetradentate ligand. In some embodiments, the compound has a neutral charge.

According to another embodiment, a first device is also provided. The first device includes a first organic light emitting device, that includes an anode, a cathode, and an organic layer disposed between the anode and the cathode. The emissive layer can include a host and a phosphorescent dopant. The organic layer can include an Ir/Pt complex including a first Ir moiety and a first Pt moiety, and any of the variations of such a compound as described herein.

According to still another embodiment, a method of forming a first device is provided. The method can include providing a first electrode disposed on a substrate; forming a first organic layer over the first electrode, wherein the first organic layer comprises the first compound; and forming a second electrode disposed over the first organic layer. The first compound includes a first Ir moiety and a first Pt moiety, and any of the variations of such compound as described herein.

#### BRIEF DESCRIPTION OF THE DRAWINGS

FIG. 1 shows an organic light emitting device.

FIG. 2 shows an inverted organic light emitting device that does not have a separate electron transport layer.

FIG. 3(a) through 3(k) show schematic representations of examples of Ir/Pt metal complexes as disclosed herein.

FIG. 4 includes molecular orbital diagrams showing the LUMO (right) and HOMO (left) for Compound 1.

FIG. 5 shows several compounds and example designations for Ir moieties and Pt moieties included in each compound.

#### DETAILED DESCRIPTION

Generally, an OLED comprises at least one organic layer disposed between and electrically connected to an anode and a cathode. When a current is applied, the anode injects holes and the cathode injects electrons into the organic layer(s). The injected holes and electrons each migrate toward the oppositely charged electrode. When an electron and hole localize on the same molecule, an "exciton," which is a localized electron-hole pair having an excited energy state, is formed. Light is emitted when the exciton relaxes via a photoemissive mechanism. In some cases, the exciton may be localized on an excimer or an exciplex. Non-radiative mechanisms, such as thermal relaxation, may also occur, but are generally considered undesirable.

The initial OLEDs used emissive molecules that emitted light from their singlet states ("fluorescence") as disclosed, for example, in U.S. Pat. No. 4,769,292, which is incorporated by reference in its entirety. Fluorescent emission generally occurs in a time frame of less than 10 nanoseconds.

More recently, OLEDs having emissive materials that emit light from triplet states ("phosphorescence") have been demonstrated. Baldo et al., "Highly Efficient Phosphorescent Emission from Organic Electroluminescent Devices," *Nature*, vol. 395, 151-154, 1998; ("Baldo-I") and Baldo et al., "Very high-efficiency green organic light-emitting devices based on electrophosphorescence," *Appl. Phys. Lett.*, vol. 75, No. 3, 4-6 (1999) ("Baldo-II"), which are incorporated by reference in their entireties. Phosphorescence is described in more detail in U.S. Pat. No. 7,279,704 at cols. 5-6, which are incorporated by reference.

FIG. 1 shows an organic light emitting device 100. The figures are not necessarily drawn to scale. Device 100 may include a substrate 110, an anode 115, a hole injection layer 120, a hole transport layer 125, an electron blocking layer 130, an emissive layer 135, a hole blocking layer 140, an electron transport layer 145, an electron injection layer 150, a protective layer 155, a cathode 160, and a barrier layer 170. Cathode 160 is a compound cathode having a first conductive layer 162 and a second conductive layer 164. Device 100 may be fabricated by depositing the layers described, in order. The properties and functions of these various layers, as well as example materials, are described in more detail in U.S. Pat. No. 7,279,704 at cols. 6-10, which are incorporated by reference.

More examples for each of these layers are available. For example, a flexible and transparent substrate-anode combination is disclosed in U.S. Pat. No. 5,844,363, which is incorporated by reference in its entirety. An example of a p-doped hole transport layer is m-MTDATA doped with F<sub>4</sub>-TCNQ at a molar ratio of 50:1, as disclosed in U.S. Patent Application Publication No. 2003/0230980, which is incorporated by reference in its entirety. Examples of emissive and host materials are disclosed in U.S. Pat. No. 6,303,238 to Thompson et al., which is incorporated by reference in its entirety. An example of an n-doped electron transport layer is BPhen doped with Li at a molar ratio of 1:1, as disclosed in U.S. Patent Application Publication No. 2003/0230980, which is incorporated by reference in its entirety. U.S. Pat. Nos. 5,703,436 and 5,707,745, which are incorporated by reference in their entireties, disclose examples of cathodes including compound cathodes having a thin layer of metal such as Mg:Ag with an overlying transparent, electrically-conductive, sputter-deposited ITO layer. The theory and use of blocking layers is described in more detail in U.S. Pat. No. 6,097,147 and U.S. Patent Application Publication No. 2003/0230980, which are incorporated by reference in their entireties. Examples of injection layers are provided in U.S. Patent Application Publication No. 2004/0174116, which is incorporated by reference in its entirety. A description of protective layers may be found in U.S. Patent Application Publication No. 2004/0174116, which is incorporated by reference in its entirety.

FIG. 2 shows an inverted OLED 200. The device includes a substrate 210, a cathode 215, an emissive layer 220, a hole transport layer 225, and an anode 230. Device 200 may be fabricated by depositing the layers described, in order. Because the most common OLED configuration has a cathode disposed over the anode, and device 200 has cathode 215 disposed under anode 230, device 200 may be referred to as an "inverted" OLED. Materials similar to those described with respect to device 100 may be used in the corresponding layers of device 200. FIG. 2 provides one example of how some layers may be omitted from the structure of device 100.

The simple layered structure illustrated in FIGS. 1 and 2 is provided by way of non-limiting example, and it is

understood that embodiments of the invention may be used in connection with a wide variety of other structures. The specific materials and structures described are exemplary in nature, and other materials and structures may be used. Functional OLEDs may be achieved by combining the various layers described in different ways, or layers may be omitted entirely, based on design, performance, and cost factors. Other layers not specifically described may also be included. Materials other than those specifically described may be used. Although many of the examples provided herein describe various layers as comprising a single material, it is understood that combinations of materials, such as a mixture of host and dopant, or more generally a mixture, may be used. Also, the layers may have various sublayers. The names given to the various layers herein are not intended to be strictly limiting. For example, in device **200**, hole transport layer **225** transports holes and injects holes into emissive layer **220**, and may be described as a hole transport layer or a hole injection layer. In one embodiment, an OLED may be described as having an "organic layer" disposed between a cathode and an anode. This organic layer may comprise a single layer, or may further comprise multiple layers of different organic materials as described, for example, with respect to FIGS. **1** and **2**.

Structures and materials not specifically described may also be used, such as OLEDs comprised of polymeric materials (PLEDs) such as disclosed in U.S. Pat. No. 5,247,190 to Friend et al., which is incorporated by reference in its entirety. By way of further example, OLEDs having a single organic layer may be used. OLEDs may be stacked, for example as described in U.S. Pat. No. 5,707,745 to Forrest et al, which is incorporated by reference in its entirety. The OLED structure may deviate from the simple layered structure illustrated in FIGS. **1** and **2**. For example, the substrate may include an angled reflective surface to improve out-coupling, such as a mesa structure as described in U.S. Pat. No. 6,091,195 to Forrest et al., and/or a pit structure as described in U.S. Pat. No. 5,834,893 to Bulovic et al., which are incorporated by reference in their entireties.

Unless otherwise specified, any of the layers of the various embodiments may be deposited by any suitable method. For the organic layers, preferred methods include thermal evaporation, ink-jet, such as described in U.S. Pat. Nos. 6,013,982 and 6,087,196, which are incorporated by reference in their entireties, organic vapor phase deposition (OVPD), such as described in U.S. Pat. No. 6,337,102 to Forrest et al., which is incorporated by reference in its entirety, and deposition by organic vapor jet printing (OVJP), such as described in U.S. Pat. No. 7,431,968, which is incorporated by reference in its entirety. Other suitable deposition methods include spin coating and other solution based processes. Solution based processes are preferably carried out in nitrogen or an inert atmosphere. For the other layers, preferred methods include thermal evaporation. Preferred patterning methods include deposition through a mask, cold welding such as described in U.S. Pat. Nos. 6,294,398 and 6,468,819, which are incorporated by reference in their entireties, and patterning associated with some of the deposition methods such as ink jet and OVJD. Other methods may also be used. The materials to be deposited may be modified to make them compatible with a particular deposition method. For example, substituents such as alkyl and aryl groups, branched or unbranched, and preferably containing at least 3 carbons, may be used in small molecules to enhance their ability to undergo solution processing. Substituents having 20 carbons or more may be used, and 3-20 carbons is a preferred range. Materials with asym-

metric structures may have better solution processibility than those having symmetric structures, because asymmetric materials may have a lower tendency to recrystallize. Dendrimer substituents may be used to enhance the ability of small molecules to undergo solution processing.

Devices fabricated in accordance with embodiments of the present invention may further optionally comprise a barrier layer. One purpose of the barrier layer is to protect the electrodes and organic layers from damaging exposure to harmful species in the environment including moisture, vapor and/or gases, etc. The barrier layer may be deposited over, under or next to a substrate, an electrode, or over any other parts of a device including an edge. The barrier layer may comprise a single layer, or multiple layers. The barrier layer may be formed by various known chemical vapor deposition techniques and may include compositions having a single phase as well as compositions having multiple phases. Any suitable material or combination of materials may be used for the barrier layer. The barrier layer may incorporate an inorganic or an organic compound or both. The preferred barrier layer comprises a mixture of a polymeric material and a non-polymeric material as described in U.S. Pat. No. 7,968,146, PCT Pat. Application Nos. PCT/US2007/023098 and PCT/US2009/042829, which are herein incorporated by reference in their entireties. To be considered a "mixture", the aforesaid polymeric and non-polymeric materials comprising the barrier layer should be deposited under the same reaction conditions and/or at the same time. The weight ratio of polymeric to non-polymeric material may be in the range of 95:5 to 5:95. The polymeric material and the non-polymeric material may be created from the same precursor material. In one example, the mixture of a polymeric material and a non-polymeric material consists essentially of polymeric silicon and inorganic silicon.

Devices fabricated in accordance with embodiments of the invention may be incorporated into a wide variety of consumer products, including flat panel displays, computer monitors, medical monitors, televisions, billboards, lights for interior or exterior illumination and/or signaling, heads up displays, fully transparent displays, flexible displays, laser printers, telephones, cell phones, personal digital assistants (PDAs), laptop computers, digital cameras, camcorders, viewfinders, micro-displays, 3-D displays, vehicles, a large area wall, theater or stadium screen, or a sign. Various control mechanisms may be used to control devices fabricated in accordance with the present invention, including passive matrix and active matrix. Many of the devices are intended for use in a temperature range comfortable to humans, such as 18 degrees C. to 30 degrees C., and more preferably at room temperature (20-25 degrees C.), but could be used outside this temperature range, for example, from -40 degree C. to +80 degree C.

The materials and structures described herein may have applications in devices other than OLEDs. For example, other optoelectronic devices such as organic solar cells and organic photodetectors may employ the materials and structures. More generally, organic devices, such as organic transistors, may employ the materials and structures.

The terms halo, halogen, alkyl, cycloalkyl, alkenyl, alkynyl, aralkyl, heterocyclic group, aryl, aromatic group, and heteroaryl are known to the art, and are defined in U.S. Pat. No. 7,279,704 at cols. 31-32, which are incorporated herein by reference.

As used herein, "substituted" indicates that a substituent other than H is bonded to the relevant carbon. Thus, where  $R^B$  is monosubstituted, then one  $R^B$  must be other than H.

Similarly, where  $R^C$  is disubstituted, then two of  $R^C$  must be other than H. Similarly, where  $R^B$  is unsubstituted,  $R^B$  is hydrogen for all available positions.

Heavy metal complexes such as iridium and platinum complexes have been used as efficient emitters in PHOLEDs. Cyclometallated iridium complexes generally exhibit shallow HOMO energy levels, making them very efficient hole trappers in a doped PHOLED device. One popular mechanism of emission from these PHOLEDs is through direct charge trapping and exciton formation directly on the emitting metal complex. This mechanism renders very high device efficiency and 100% internal quantum efficiency has been demonstrated using iridium complex as the emitter. On the contrary, platinum complexes generally have deeper HOMO and LUMO levels compared to iridium complexes. Deeper HOMO makes them ineffective charge trapper and causes charge leakage in the devices, which in turn results in inefficient devices with low EQE. Examples of tetradentate platinum complexes can be found in U.S. Patent Application Publication No. 2012223634. Although high PLQY was observed from these platinum complexes, most of the devices showed low EQE except those containing a triarylamine moiety that can serve as an efficient charge trapping moiety. Unfortunately, introducing triarylamine moiety can red shift the emission of the complex, making it difficult to achieve blue color. Compared to their iridium counterpart, platinum complexes often have more accessible LUMO level. This may make them more stable toward electrons in the device, therefore, achieving stable OLED devices. This invention provides dinuclear or multinuclear iridium-platinum complexes that take the advantage of the charge trapping property of the iridium moiety and the stabilized LUMO property of the platinum moiety. These complexes can be used as emitters in PHOLEDs.

According to one embodiment, a compound that includes a first Ir moiety and a first Pt moiety is disclosed. The first Ir moiety is an Ir(III) six-coordinated structure, while the first Pt moiety is a Pt(II) four-coordinated structure. The first Pt moiety includes a tetradentate ligand. In some embodiments, the compound has a neutral charge.

As used herein, the terms "Ir moiety" and "Pt moiety" refer to an Ir core or a Pt core, respectively, forming a complex with one or more ligands that fully coordinate the metal core. Where an atom bonding the ligand to the metal core that is part of a ring or fused ring system, the ligand includes the atom and the entire ring or fused ring system that of which the atom is a part. Examples of Ir moieties and Pt moieties are shown in FIG. 5. The portions not circled in FIG. 5 are organic moieties (e.g., linkers). The ligands complexed to the Ir or Pt core can be monodentate, bidentate or multidentate. In some embodiments, at least one ligand in each Ir moiety or Pt moiety is at least bidentate (i.e., is not monodentate). The Ir and Pt moieties disclosed herein can have a neutral charge or can have a non-neutral charge (e.g., +3, +2, +1, -1, -2, -3, etc.).

In some embodiments, the first Ir moiety comprises an Ir tris-bidentate structure. The ligands comprising the Ir moieties described herein can include, but are not limited to hexadentate structures, tridentate structures, bidentate structures and monodentate structures. In some embodiments, the Ir moieties disclosed herein can be homoleptic, while they can be heteroleptic in other embodiments.

In some embodiments, the compound also includes an organic moiety. Where present, the organic moiety can link the first Ir moiety and the first Pt moiety together. In some

embodiments, the organic moiety includes a chemical group selected from the group consisting of alkyl, cycloalkyl, heteroalkyl, arylalkyl, alkoxy, aryloxy, amino, silyl, alkenyl, cycloalkenyl, heteroalkenyl, alkynyl, aryl, heteroaryl, and combinations thereof. The organic moiety can include a chemical group selected from the group consisting of alkyl, cycloalkyl, amino, silyl, aryl, heteroaryl and combinations thereof. The organic moiety comprises a chemical group selected from the group consisting of methyl, ethyl, propyl, 1-methylethyl, butyl, 1-methylpropyl, 2-methylpropyl, pentyl, 1-methylbutyl, 2-methylbutyl, 3-methylbutyl, 1,1-dimethylpropyl, 1,2-dimethylpropyl, 2,2-dimethylpropyl, cyclopentyl, cyclohexyl, phenyl, biphenyl, triphenylene, terphenyl, tetraphenyl, pentaphenyl, pyridine, phenyl pyridine, pyridyl phenyl, fluorene, carbazole, dibenzothiophene, dibenzofuran, dibenzoselenophene, azacarbazole, aza-dibenzothiophene, aza-dibenzofuran, aza-dibenzoselenophene, partially or fully deuterated variants thereof, and combinations thereof.

As an example, compounds 1-13 and 16-34 include organic moieties (i.e., linkers), while compounds 14 and 15 do not include organic moieties (i.e., linkers). In FIG. 5, the portions of Compound 1 and Compound 4 that are not circled can be considered linkers.

In some embodiments, the compound includes a second Ir moiety, a second Pt moiety, or both. In some embodiments, the total number of metal atoms in the compound is 2 to 7. In some embodiments, each of the metal atoms in the compound are Ir or Pt.

In some embodiments, the compound has an emissive spectrum having a peak wavelength of about 400 nm to about 480 nm. In some embodiments, the compound emits yellow to orange light with a full width at half maximum between about 70 nm to about 110 nm when the light has a peak wavelength between about 530 nm to about 580 nm.

In some more specific embodiments, the first Ir moiety includes an Ir six-coordinated structure having at least one ligand or part of the ligand if the ligand is more than bidentate selected from the group consisting of:

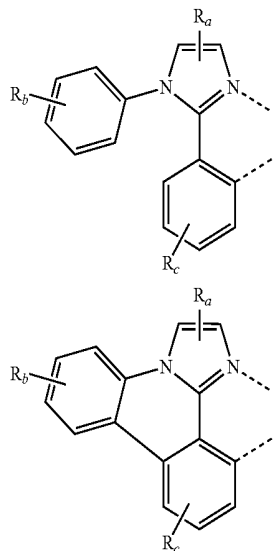

9

-continued

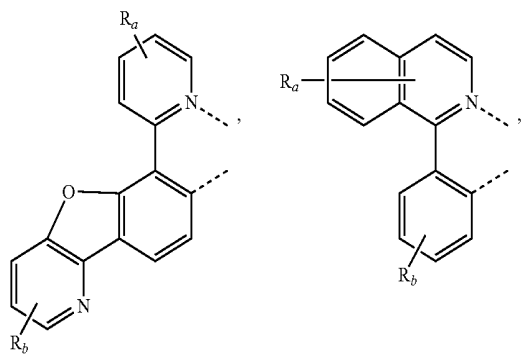
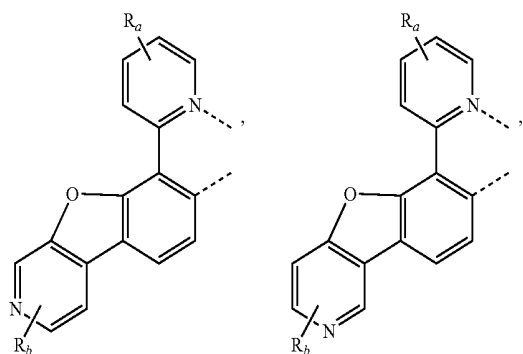
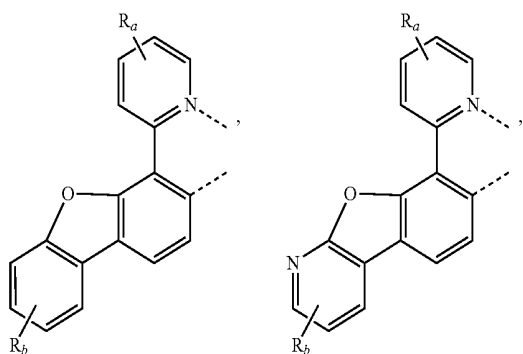
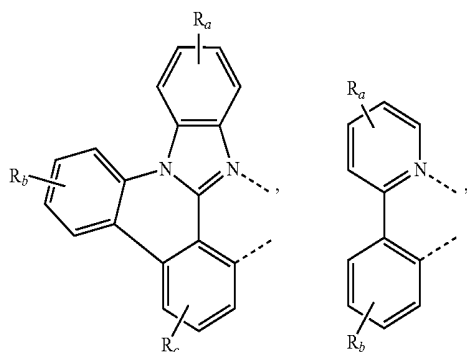
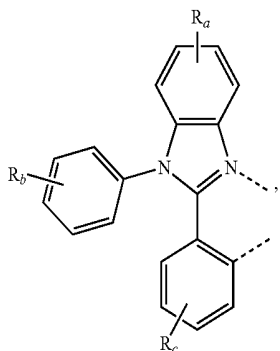

10

-continued

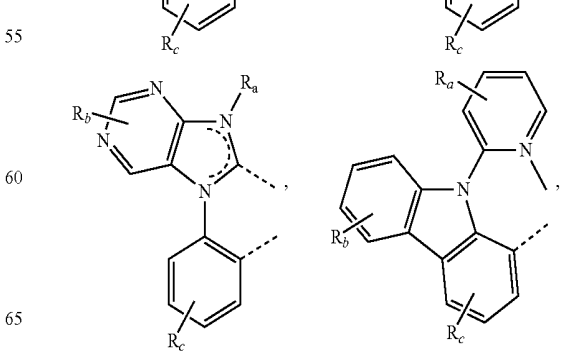
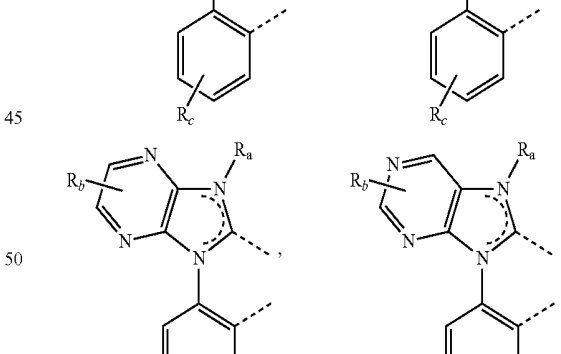
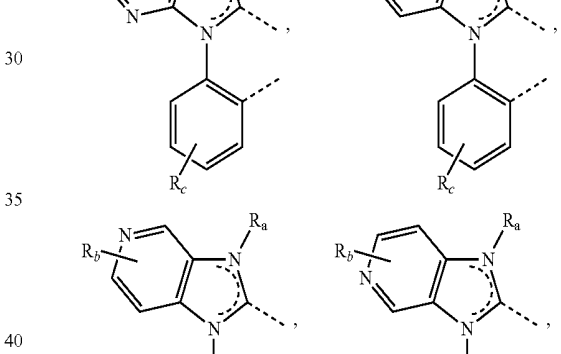
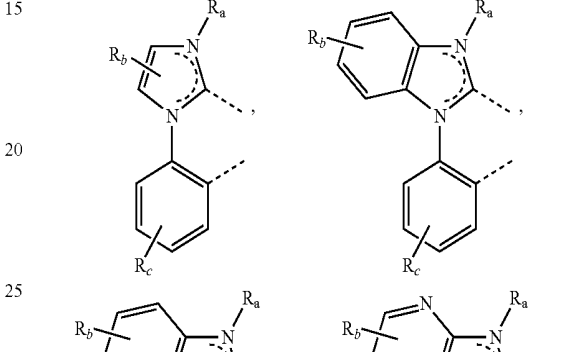
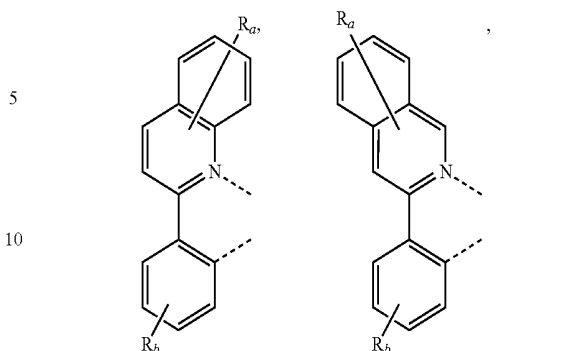

11

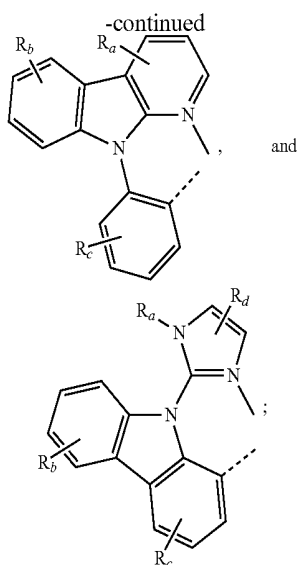

where  $R_a$ ,  $R_b$ ,  $R_c$ , and  $R_d$  may represent mono, di, tri, or tetra substitution, or no substitution;

where  $R_a$ ,  $R_b$ ,  $R_c$ , and  $R_d$  are independently selected from the group consisting of hydrogen, deuterium, halide, alkyl, cycloalkyl, heteroalkyl, arylalkyl, alkoxy, aryloxy, amino, silyl, alkenyl, cycloalkenyl, heteroalkenyl, alkynyl, aryl, heteroaryl, acyl, carbonyl, carboxylic acids, ester, nitrile, isonitrile, sulfanyl, sulfinyl, sulfonyl, phosphino, and combinations thereof; and wherein two adjacent substituents of  $R_a$ ,  $R_b$ ,  $R_c$ , and  $R_d$  are optionally joined to form a fused ring or form a multidentate ligand.

In some embodiments, the first Ir moiety includes an Ir six-coordinated structure having at least one ligand or part of the ligand if the ligand is more than bidentate selected from the group consisting of:

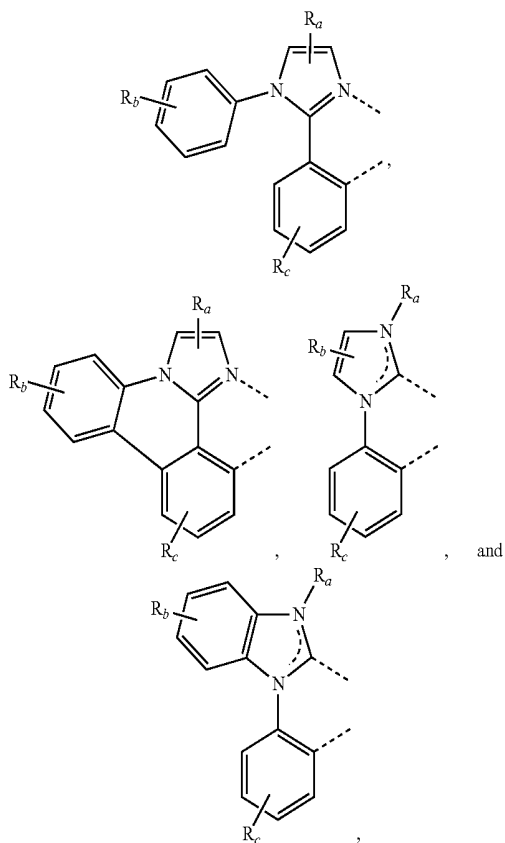

12

where  $R_a$ ,  $R_b$  and  $R_c$  may represent mono, di, tri, or tetra substitution, or no substitution;

where  $R_a$ ,  $R_b$  and  $R_c$  are independently selected from the group consisting of hydrogen, deuterium, halide, alkyl, cycloalkyl, heteroalkyl, arylalkyl, alkoxy, aryloxy, amino, silyl, alkenyl, cycloalkenyl, heteroalkenyl, alkynyl, aryl, heteroaryl, acyl, carbonyl, carboxylic acids, ester, nitrile, isonitrile, sulfanyl, sulfinyl, sulfonyl, phosphino, and combinations thereof; and wherein two adjacent substituents of  $R_a$ ,  $R_b$  and  $R_c$  are optionally joined to form a fused ring or form a multidentate ligand.

In some more specific embodiments, the first Pt moiety comprises a Pt four-coordinated structure wherein part of the ligand is selected from the group consisting of:

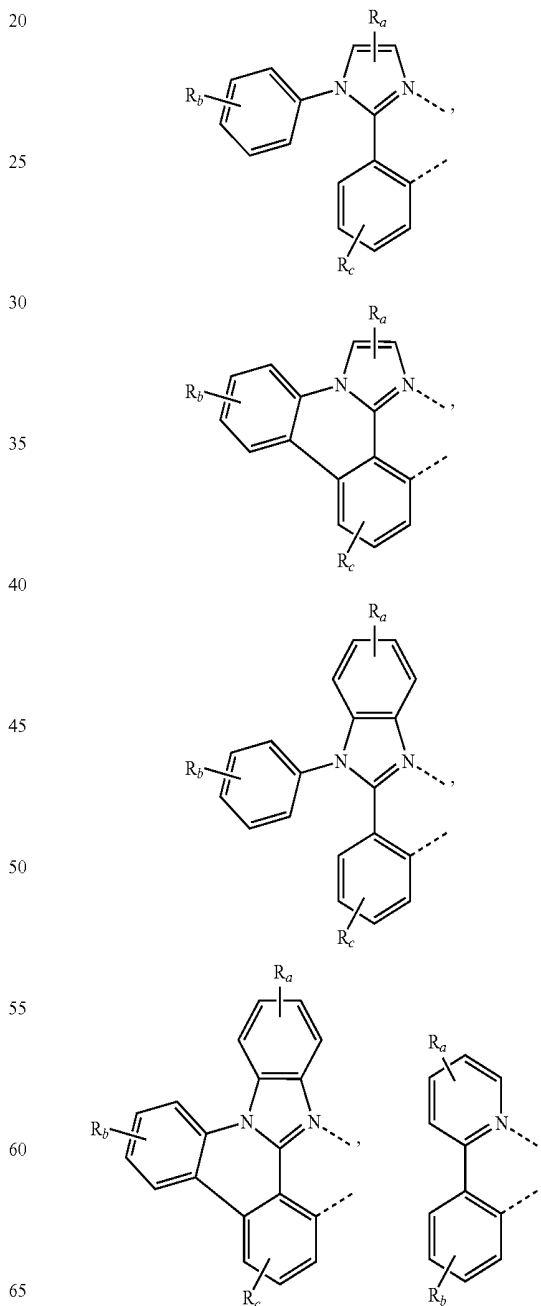

13

-continued

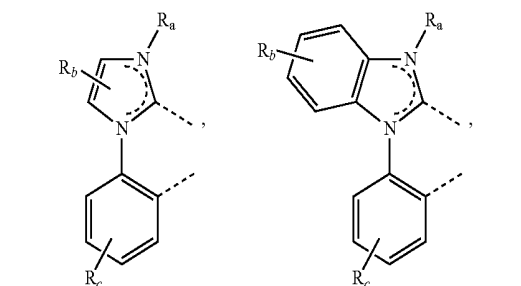
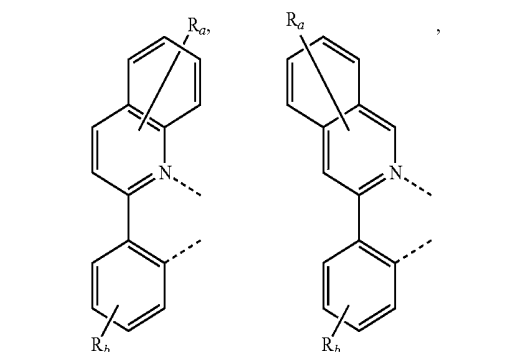
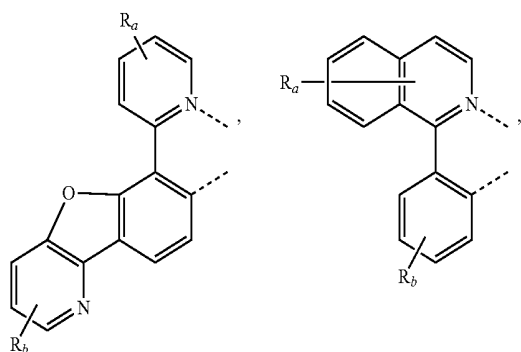
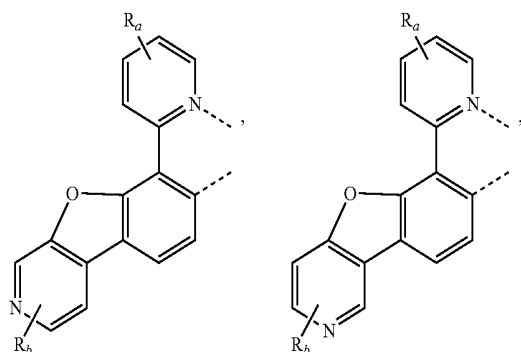
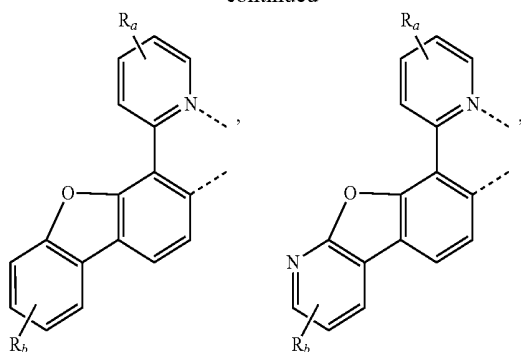

14

-continued

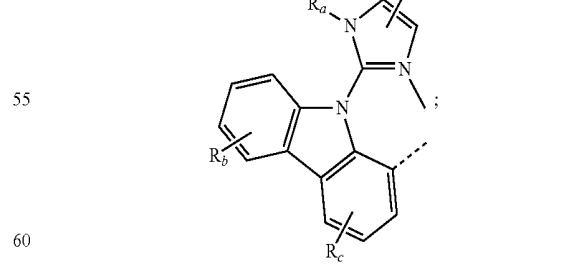
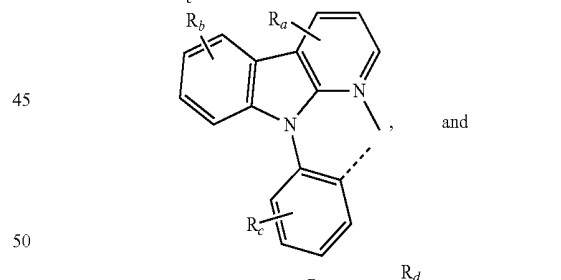
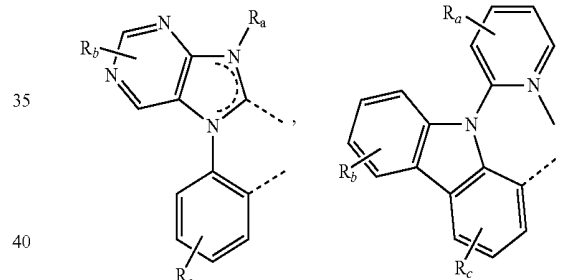
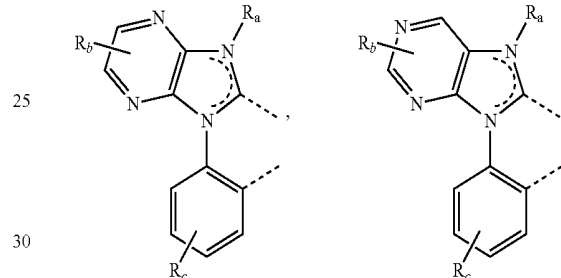
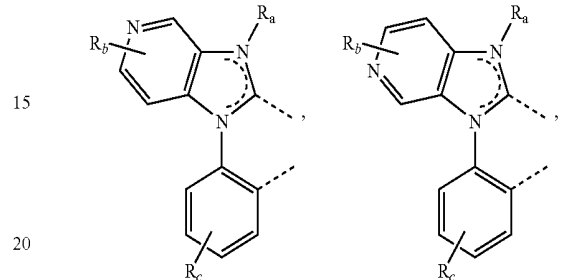
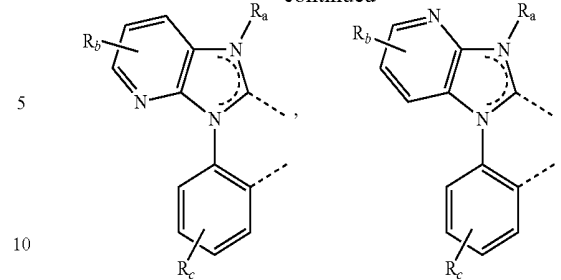

and

where  $R_a$ ,  $R_b$ ,  $R_c$ , and  $R_d$  may represent mono, di, tri, or tetra substitution, or no substitution;

65 where  $R_a$ ,  $R_b$ ,  $R_c$ , and  $R_d$  are independently selected from the group consisting of hydrogen, deuterium, halide, alkyl, cycloalkyl, heteroalkyl, arylalkyl, alkoxy, aryloxy, amino,

15

silyl, alkenyl, cycloalkenyl, heteroalkenyl, alkynyl, aryl, heteroaryl, acyl, carbonyl, carboxylic acids, ester, nitrile, isonitrile, sulfanyl, sulfinyl, sulfonyl, phosphino, and combinations thereof; and wherein two adjacent substituents of  $R_a$ ,  $R_b$ ,  $R_c$ , and  $R_d$  are optionally joined to form a fused ring or form a multidentate ligand.

In some embodiments, the first Pt moiety comprises a Pt four-coordinated structure wherein part of the ligand is selected from the group consisting of:

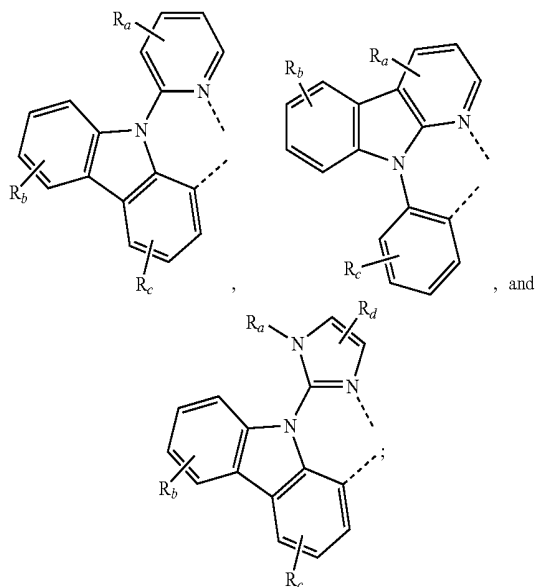

where  $R_a$ ,  $R_b$ ,  $R_c$ , and  $R_d$  may represent mono, di, tri, or tetra substitution, or no substitution;

where  $R_a$ ,  $R_b$ ,  $R_c$ , and  $R_d$  are independently selected from the group consisting of hydrogen, deuterium, halide, alkyl, cycloalkyl, heteroalkyl, arylalkyl, alkoxy, aryloxy, amino, silyl, alkenyl, cycloalkenyl, heteroalkenyl, alkynyl, aryl, heteroaryl, acyl, carbonyl, carboxylic acids, ester, nitrile, isonitrile, sulfanyl, sulfinyl, sulfonyl, phosphino, and combinations thereof; and wherein two adjacent substituents of  $R_a$ ,  $R_b$ ,  $R_c$ , and  $R_d$  are optionally joined to form a fused ring or form a multidentate ligand.

In some more specific embodiments, the compound is selected from the group consisting of:

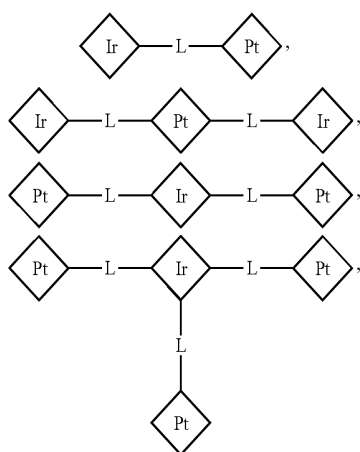

16

-continued

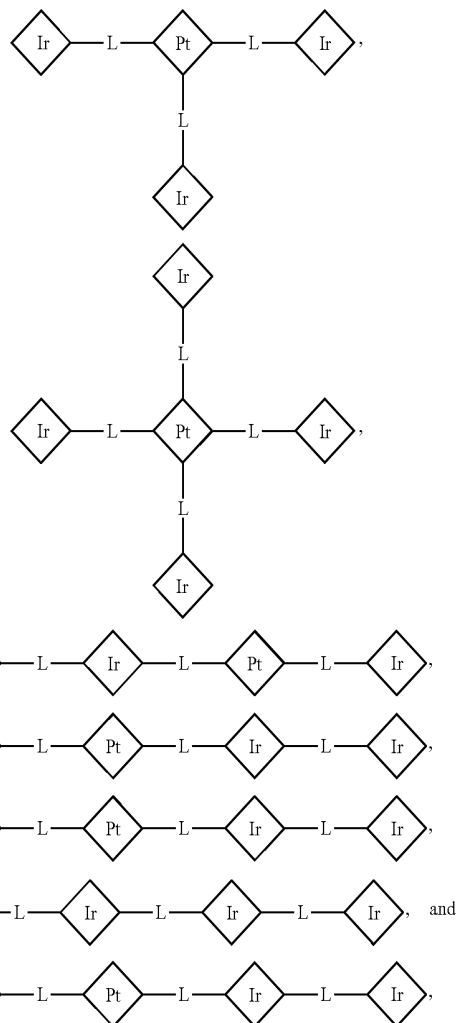

wherein



represents an Ir moiety;

wherein



represents a Pt moiety;

wherein L represents an organic moiety; and

wherein each

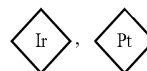

and L can be same or different.

17

In some embodiments, the first Ir moiety includes a chemical structure selected from the group consisting of:

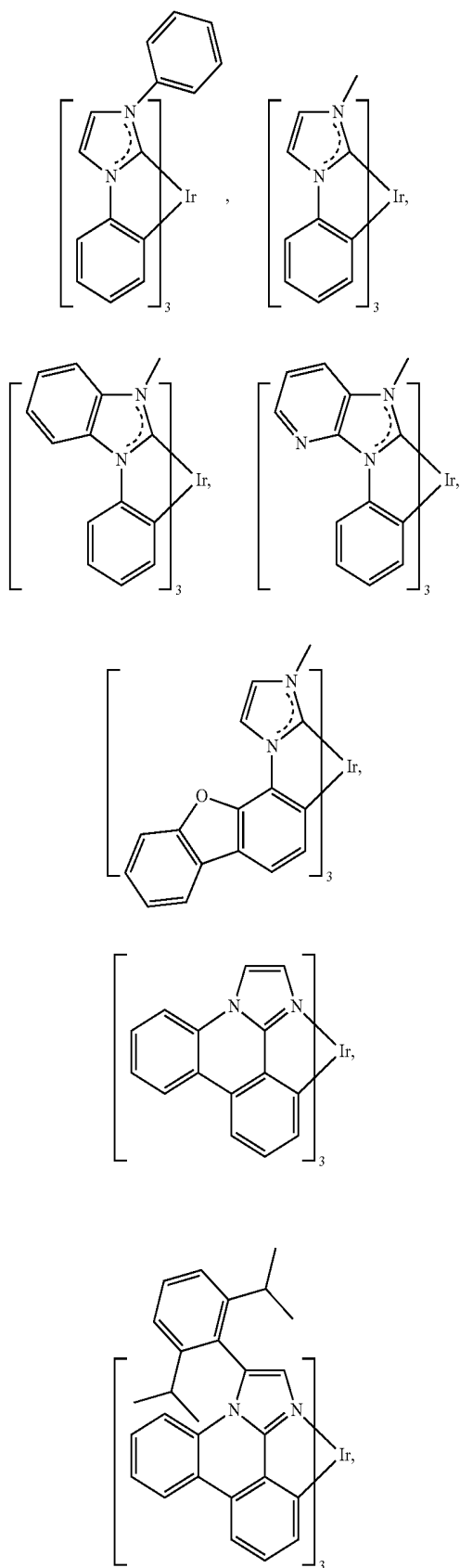

18

-continued

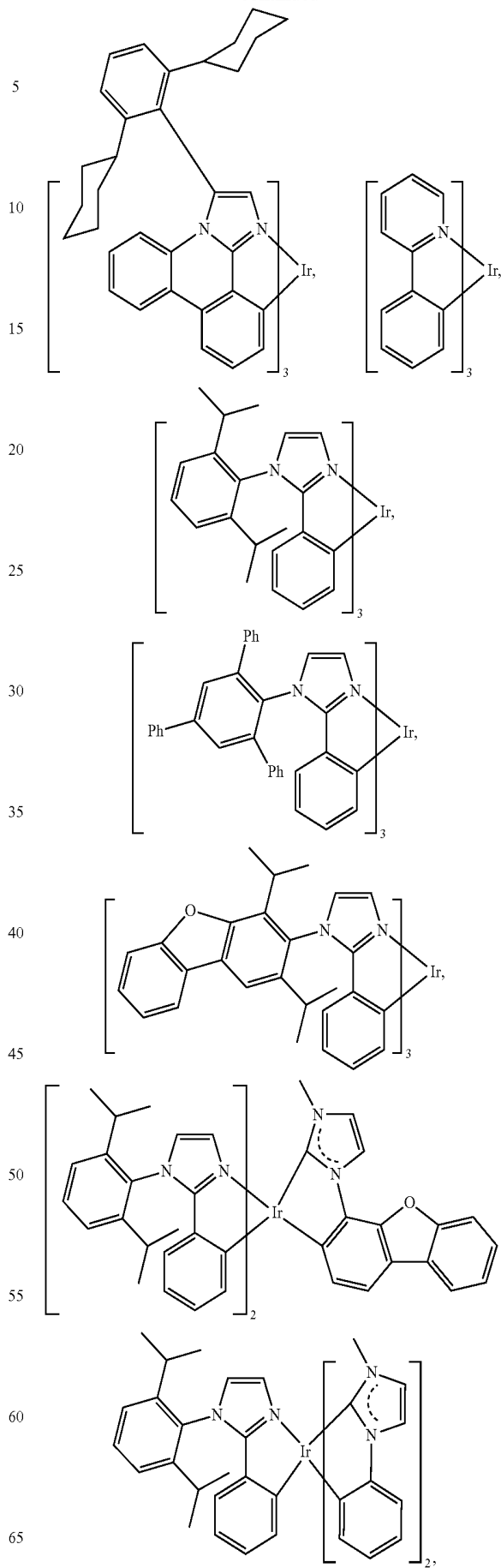

**19**  
-continued

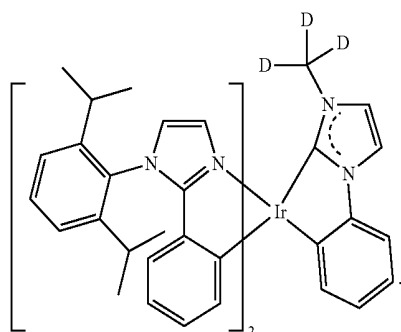
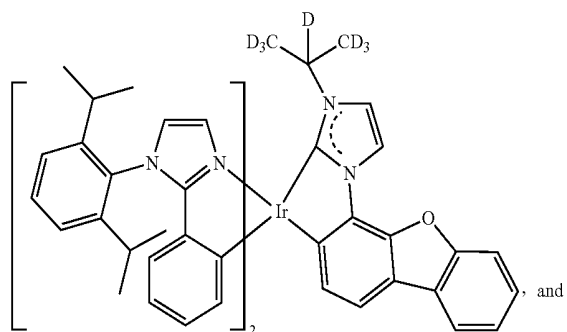

In some embodiments, the first Pt moiety includes a chemical structure selected from the group consisting of:

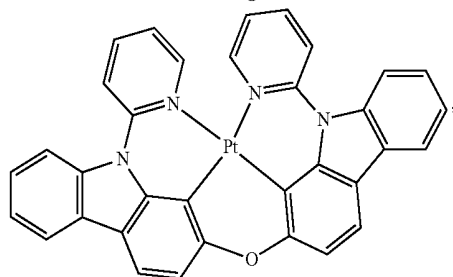
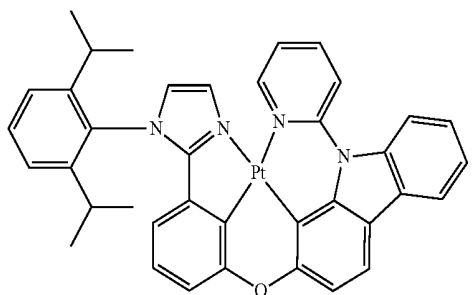
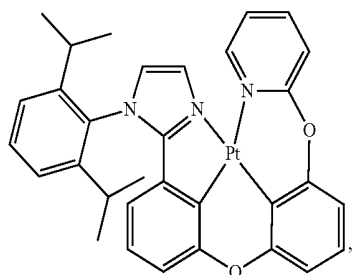

**20**  
-continued

5

10

15

20

25

30

35

40

45

50

55

60

65

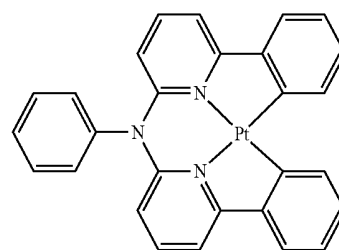
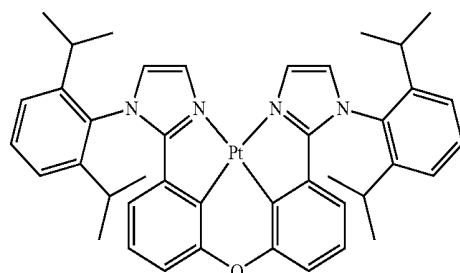
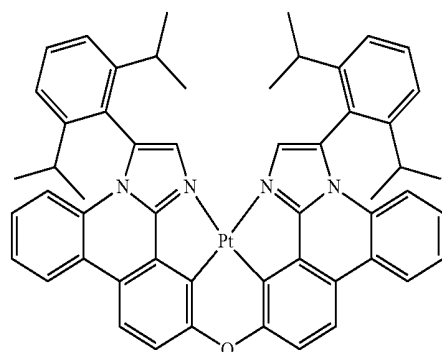
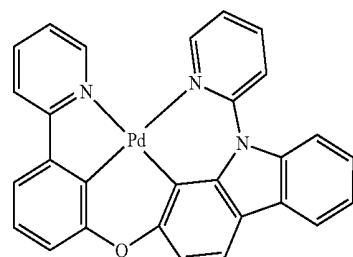
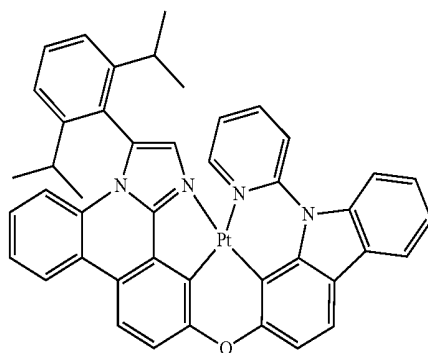

**21**  
-continued

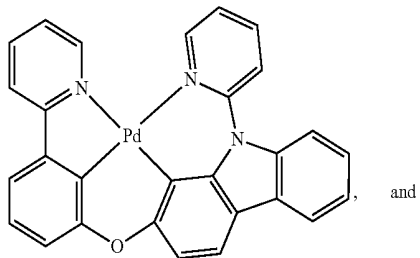

**22**  
-continued

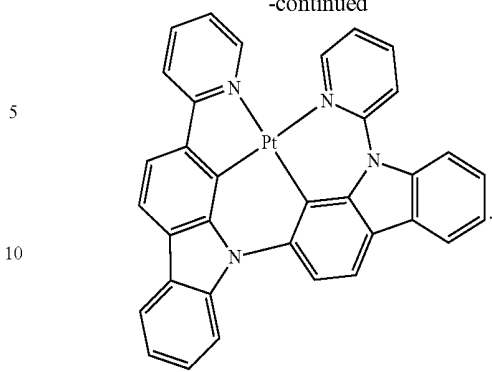

15 In some specific embodiments, the compound is selected from the group consisting of:

Compound 1

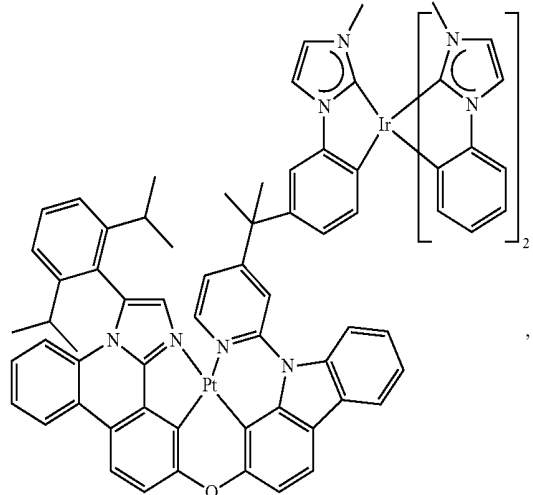

Compound 2

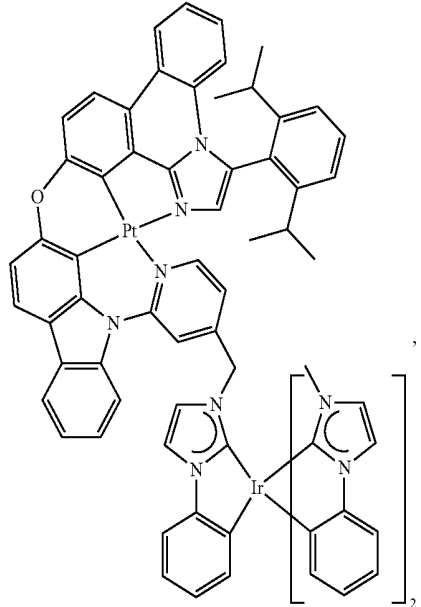

Compound 3

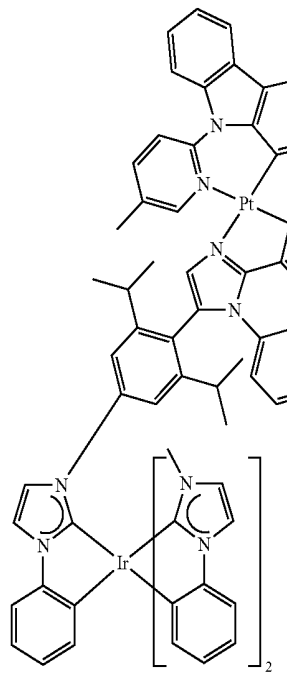



25

26

-continued

Compound 8

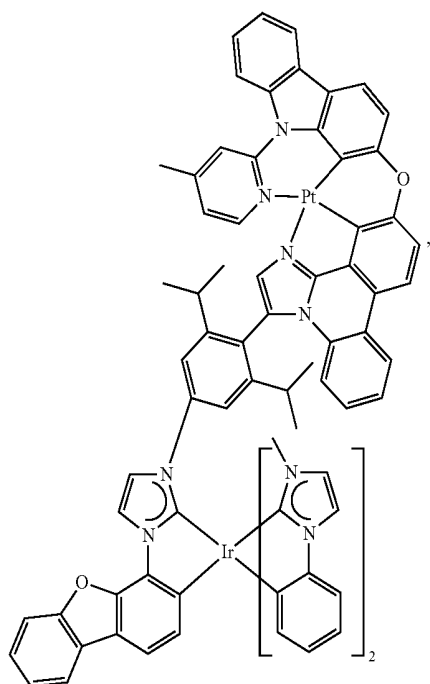

Compound 9

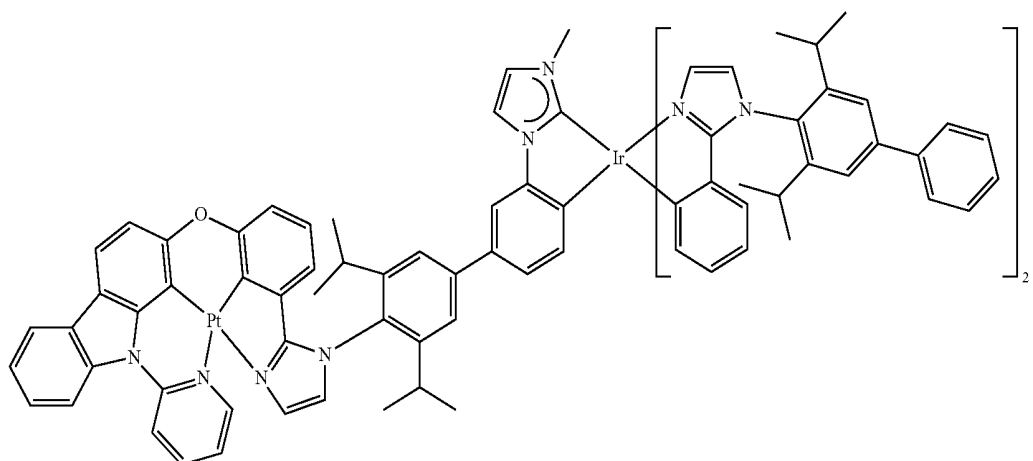

Compound 10

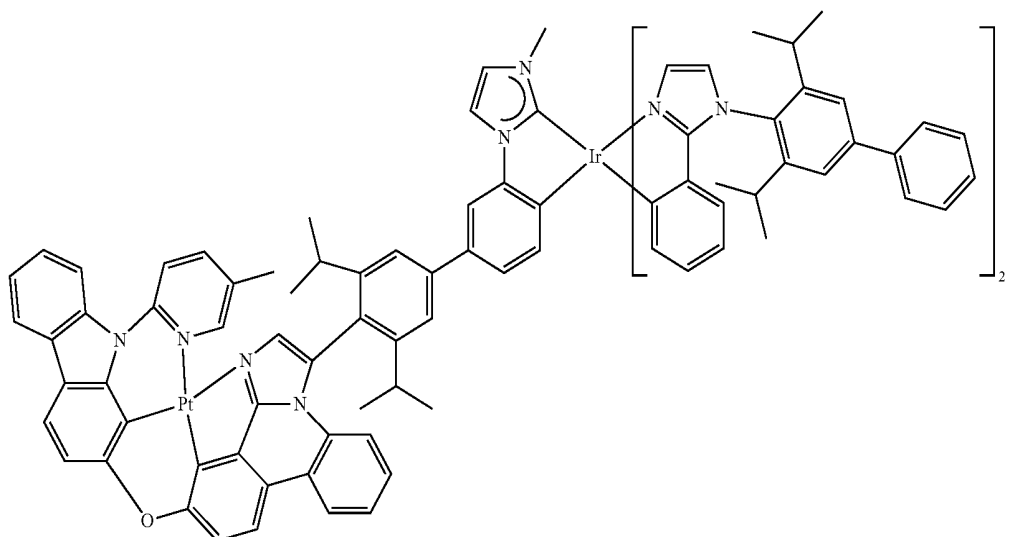

-continued

Compound 11

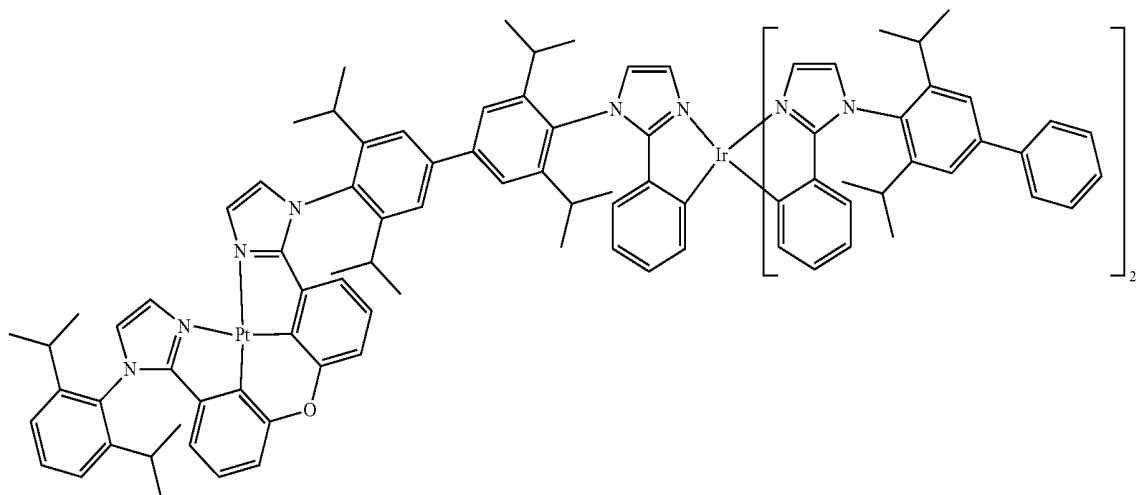

Compound 12

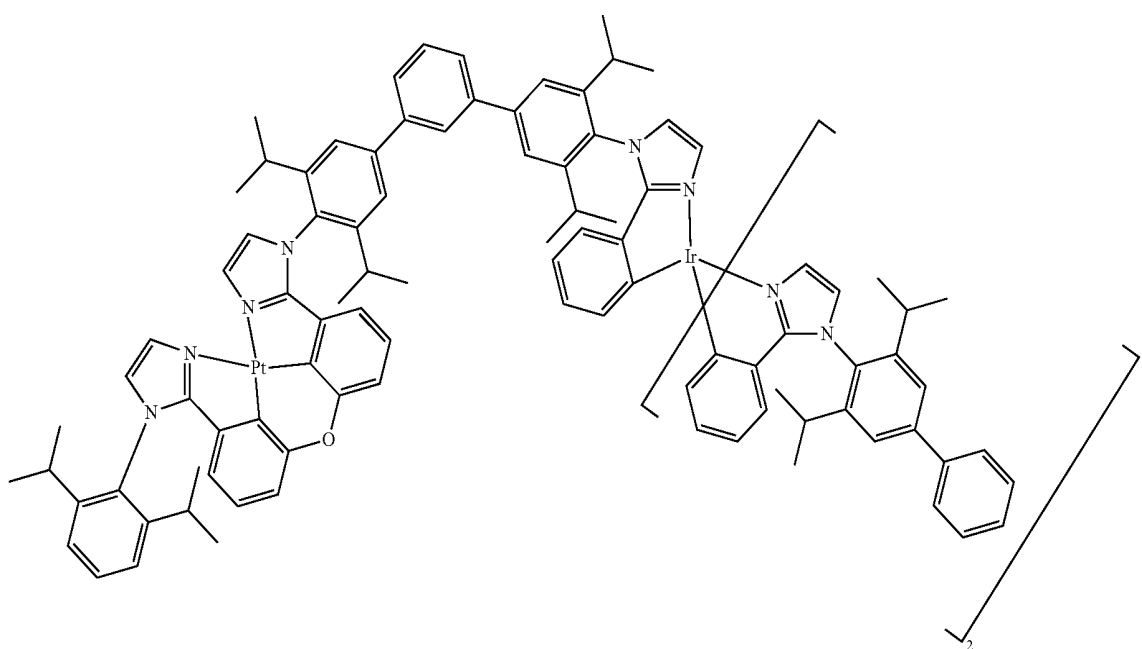

-continued

Compound 13

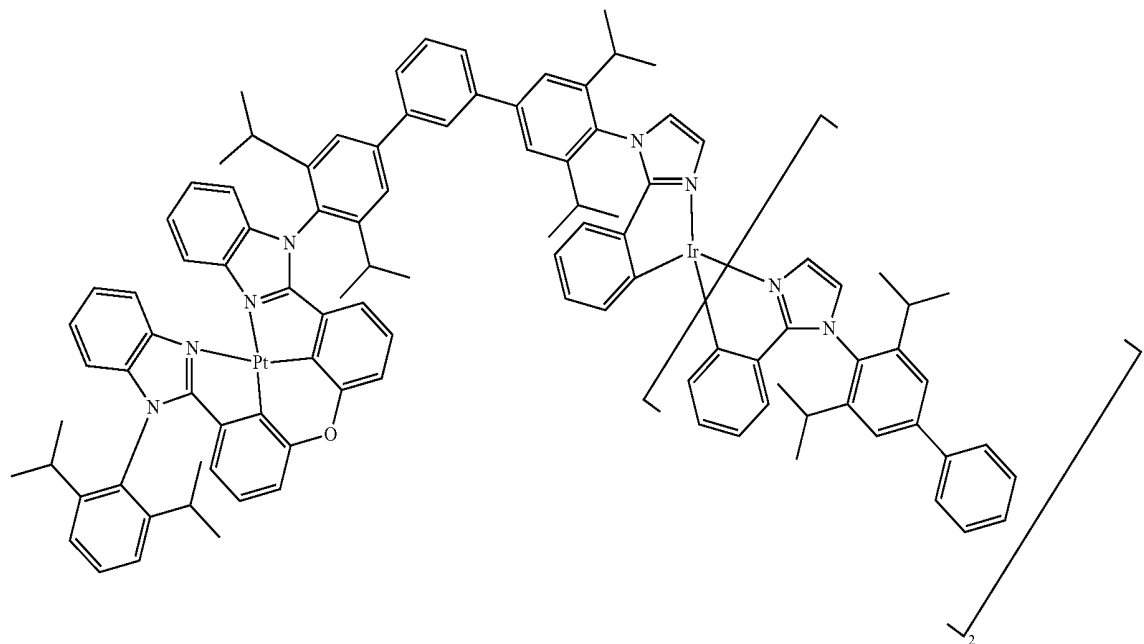

Compound 14

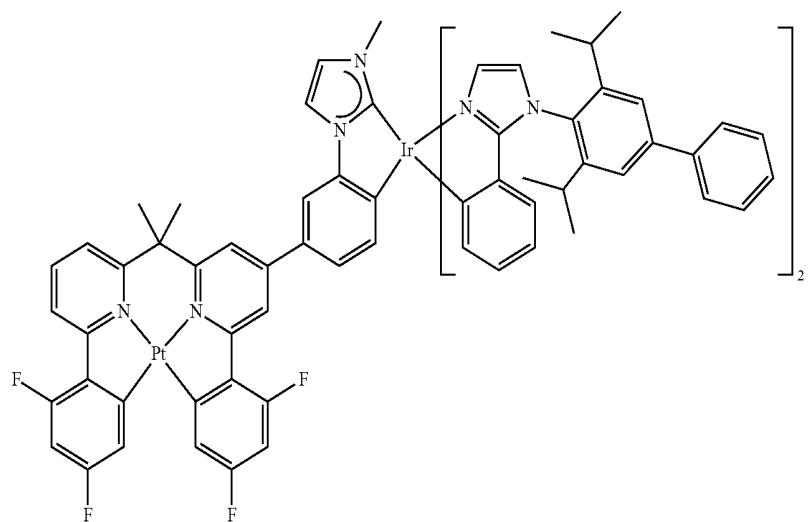

Compound 15

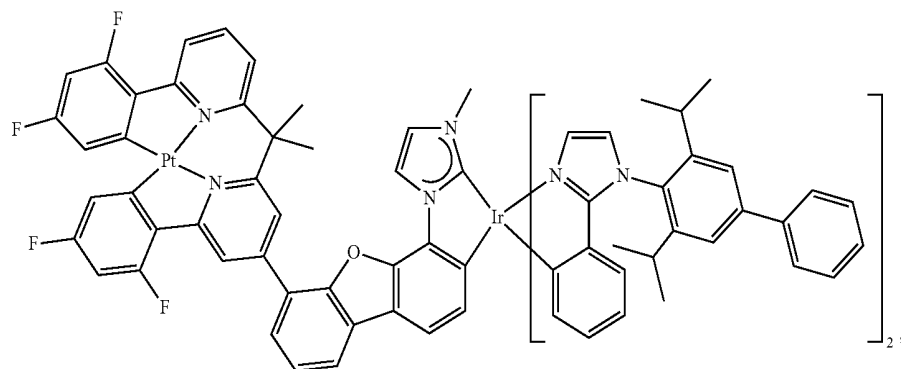

31

32

-continued

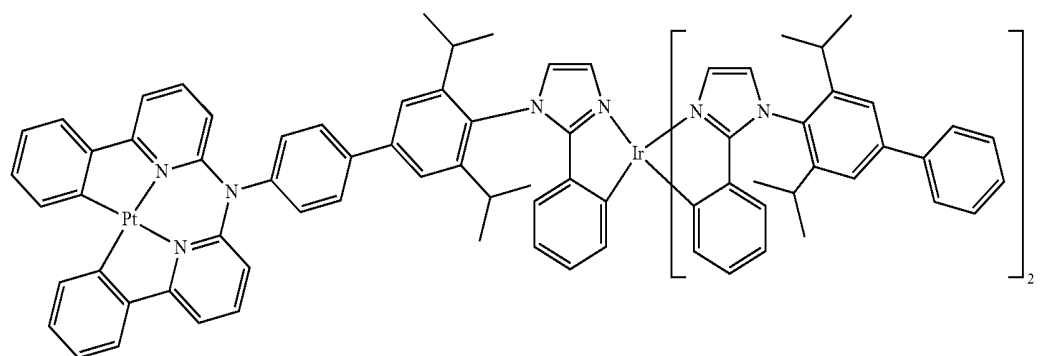

Compound 16

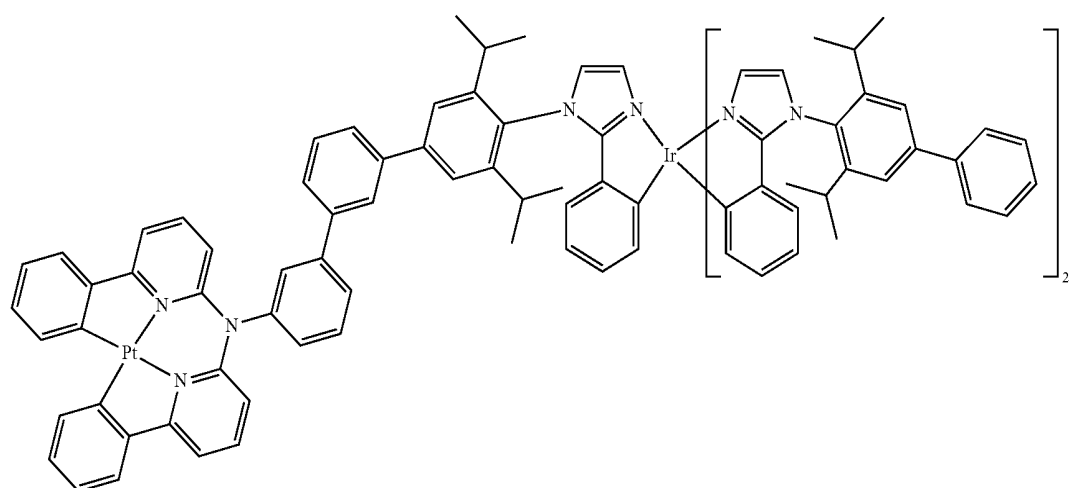

Compound 17

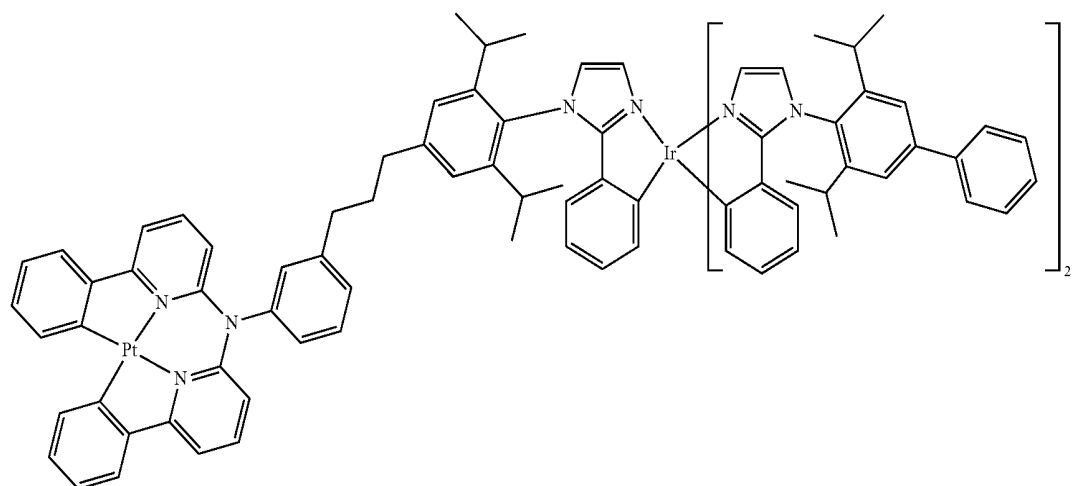

Compound 18

33

34

-continued

Compound 19

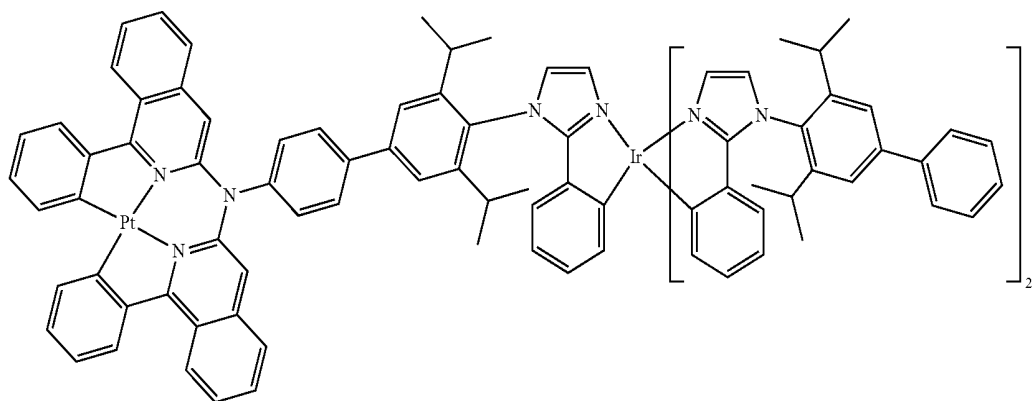

Compound 20

Compound 21

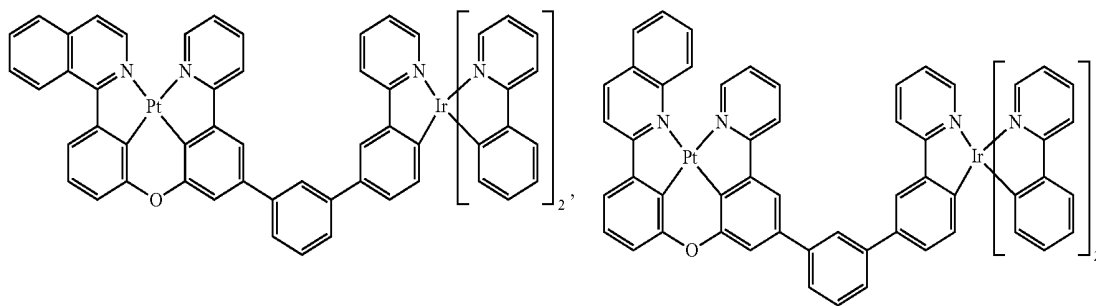

Compound 22

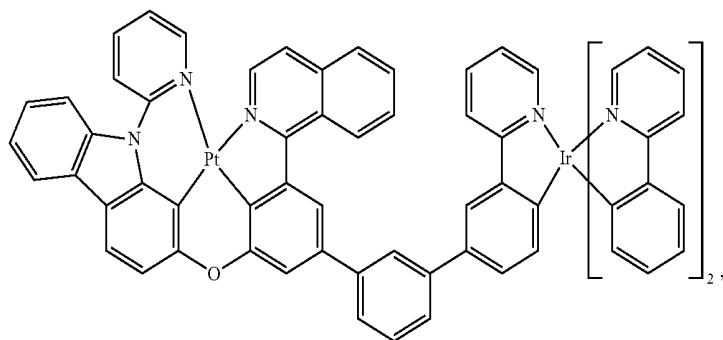

Compound 23

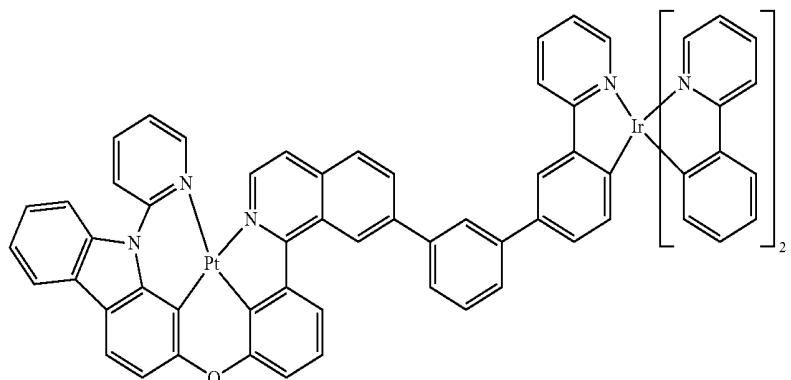

35

36

-continued

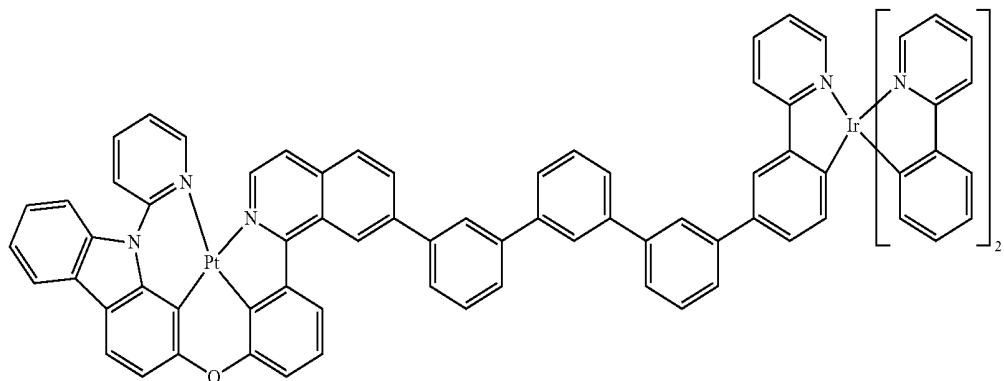

Compound 24

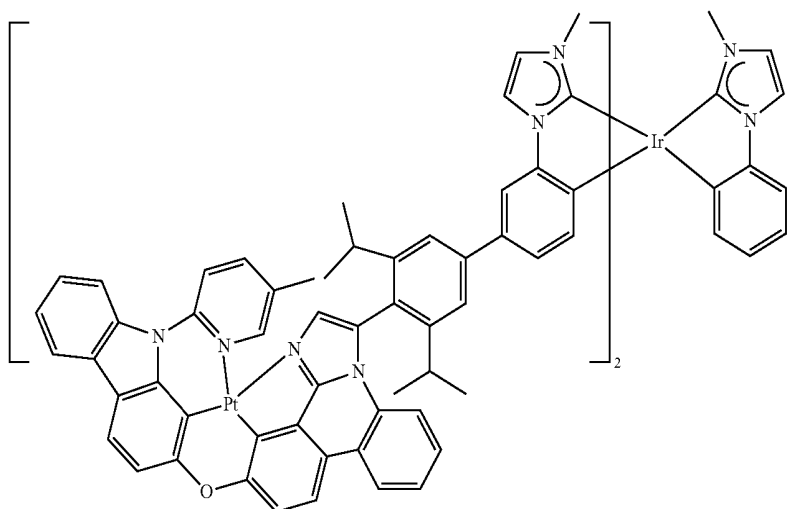

Compound 25

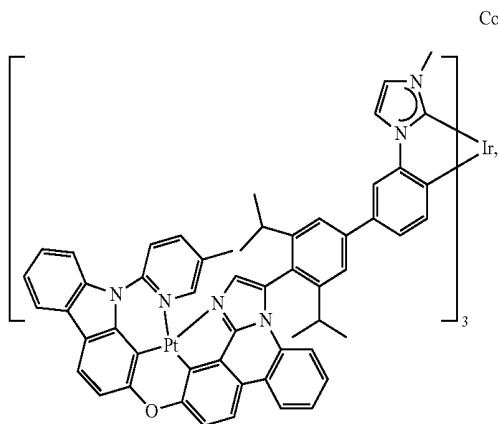

Compound 26

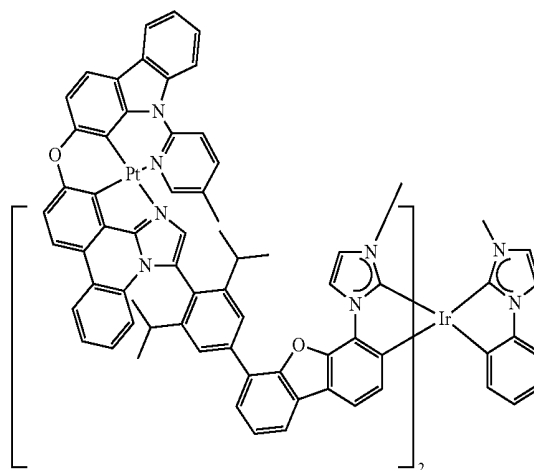

Compound 27

-continued

Compound 28

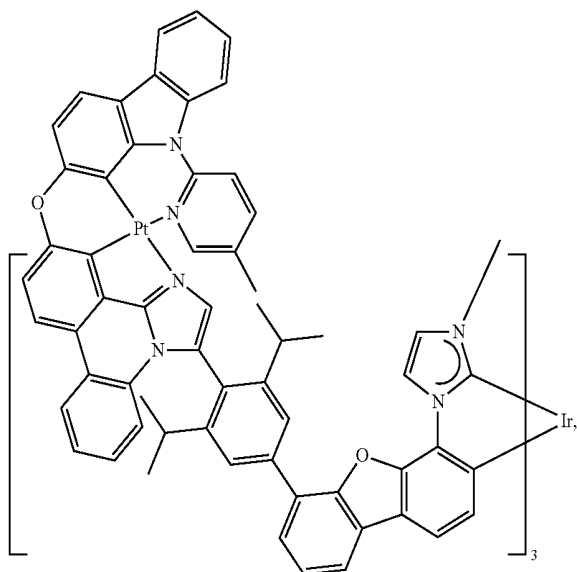

Compound 29

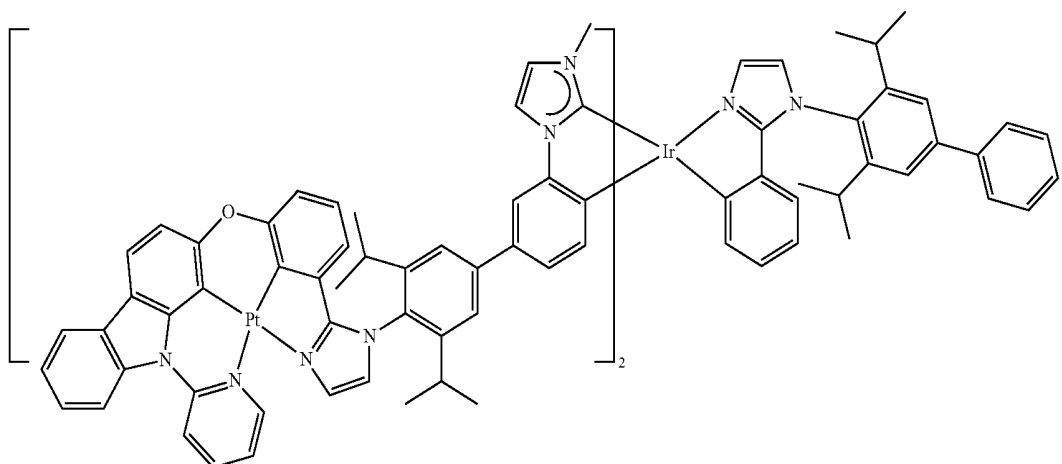

Compound 30

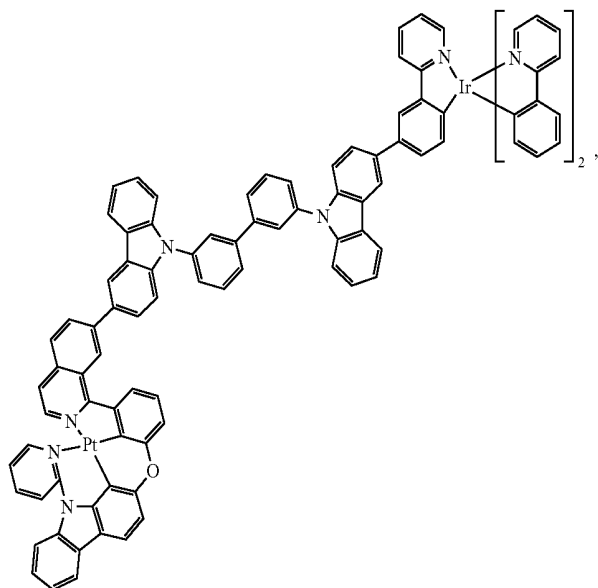

-continued

Compound 31

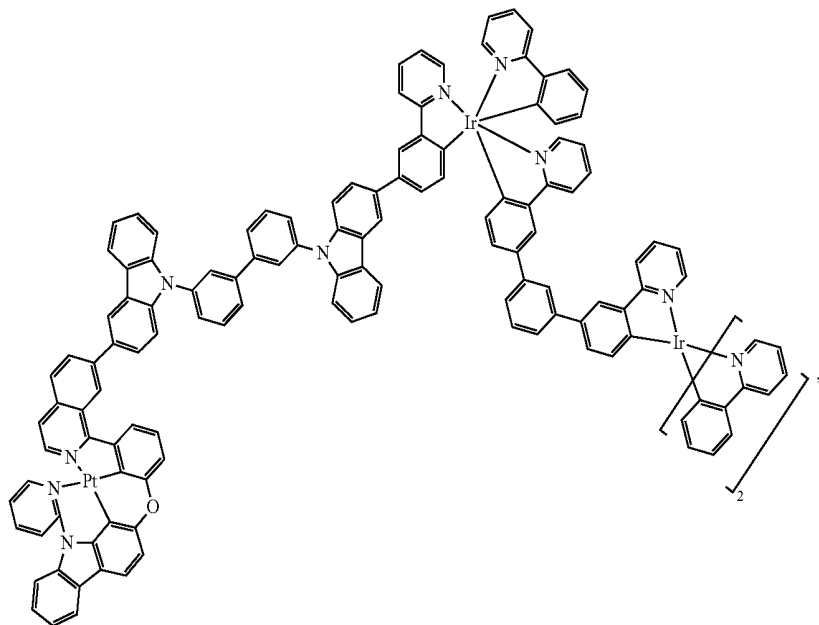

Compound 32

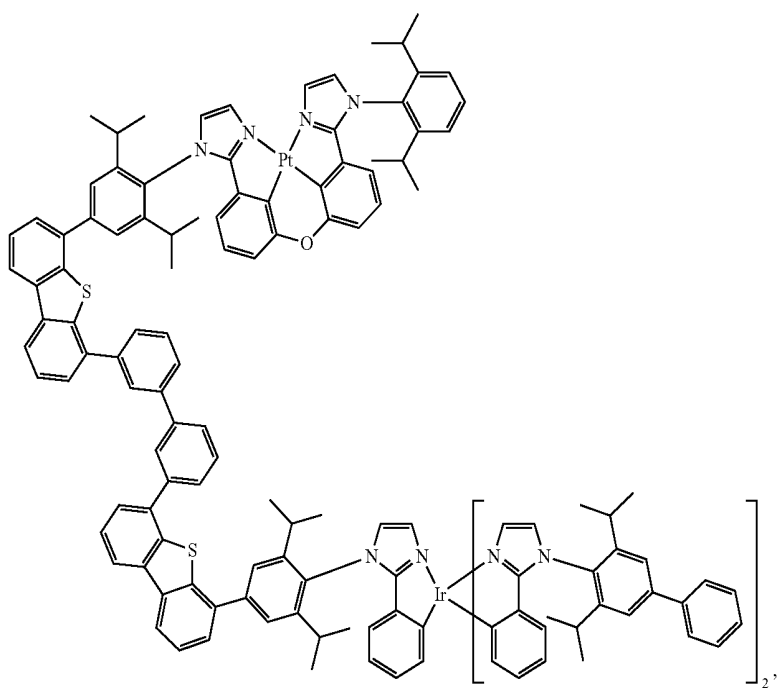

-continued

Compound 33

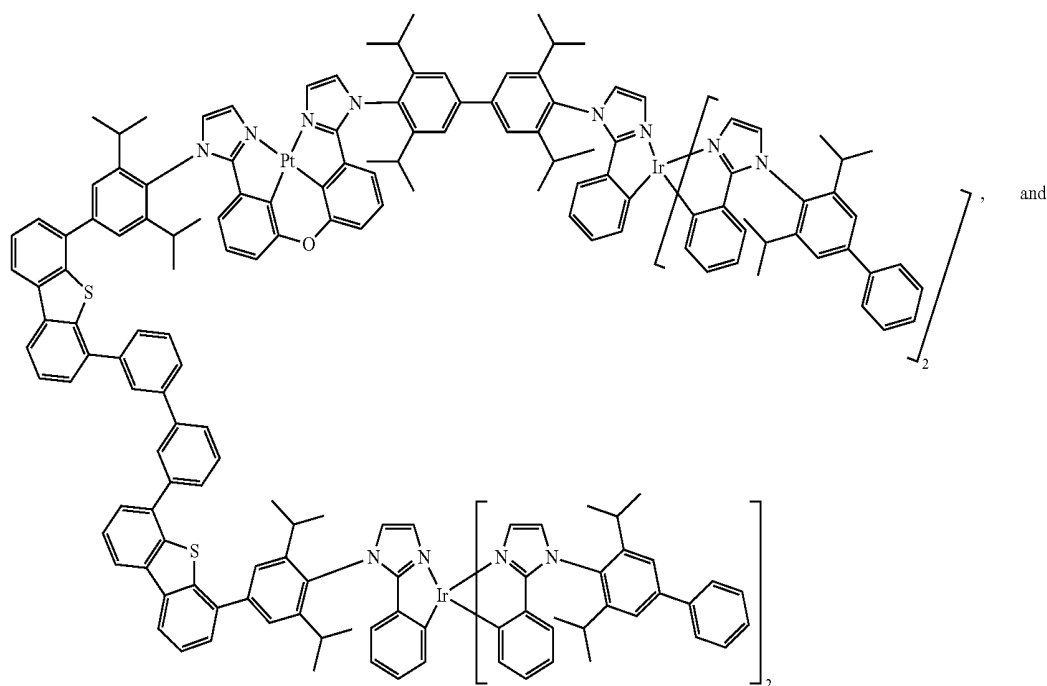

Compound 34

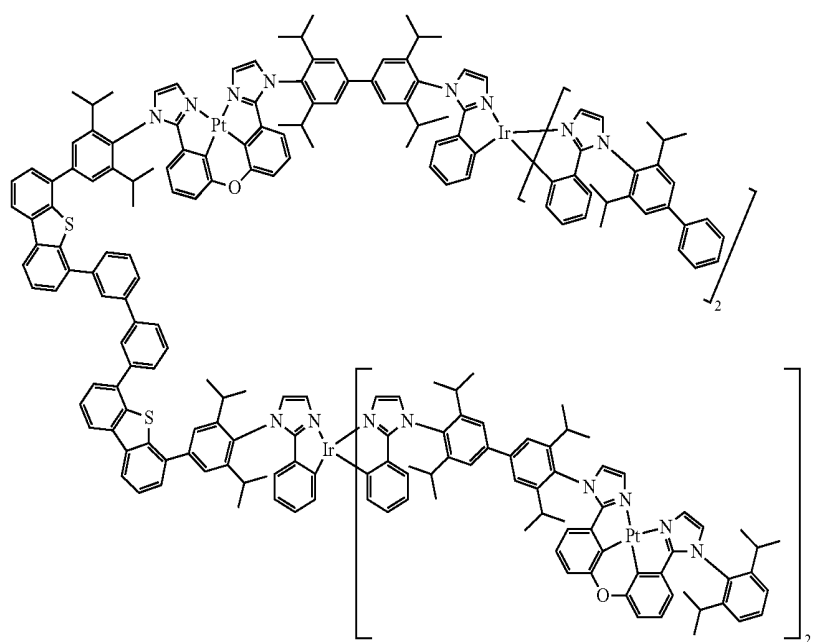

According to another aspect of the present disclosure, a first device is also provided. The first device includes a first organic light emitting device, that includes an anode, a cathode, and an organic layer disposed between the anode and the cathode. The emissive layer may include a host and a phosphorescent dopant. The organic layer can include a compound including a first Ir moiety and a first Pt moiety, and any of the variations of such a compound (i.e., an Ir/Pt metal complex) as described herein.

The first device can be one or more of a consumer product, an organic light-emitting device and a lighting panel. The organic layer can be an emissive layer and the compound can be an emissive dopant in some embodiments, while the compound can be a non-emissive dopant in other embodiments.

The organic layer can also include a host. In some embodiments, the host can include a triphenylene containing benzo-fused thiophene or benzo-fused furan. Any substituent in the host can be an unfused substituent independently selected from the group consisting of  $C_nH_{2n+1}$ ,  $OC_nH_{2n+1}$ ,  $OAr_1$ ,  $N(C_nH_{2n+1})_2$ ,  $N(Ar_1)(Ar_2)$ ,  $CH=CH-C_nH_{2n+1}$ ,  $C\equiv C-C_nH_{2n+1}$ ,  $Ar_1$ ,  $Ar_1-Ar_2$ ,  $C_nH_{2n}-Ar_1$ , or no substitution. In the preceding substituents  $n$  can range from 1 to 10; and  $Ar_1$  and  $Ar_2$  can be independently selected from the group consisting of benzene, biphenyl, naphthalene, triphenylene, carbazole, and heteroaromatic analogs thereof.

The host can be a compound selected from the group consisting of carbazole, dibenzothiophene, dibenzofuran, dibenzoselenophene, azacarbazole, aza-dibenzothiophene, aza-dibenzofuran, and aza-dibenzoselenophene. The "aza"

43

designation in the fragments described above, i.e., aza-dibenzofuran, aza-dibenzonethiophene, etc., means that one or more of the C—H groups in the respective fragment can be replaced by a nitrogen atom, for example, and without any limitation, azatriphenylene encompasses both dibenzo [f,h] quinoxaline and dibenzo[f,h] quinoline. One of ordinary skill in the art can readily envision other nitrogen analogs of the aza-derivatives described above, and all such analogs are intended to be encompassed by the terms as set forth herein. In some embodiments, the host can include a metal complex. The host can be a specific compound selected from the group consisting of:

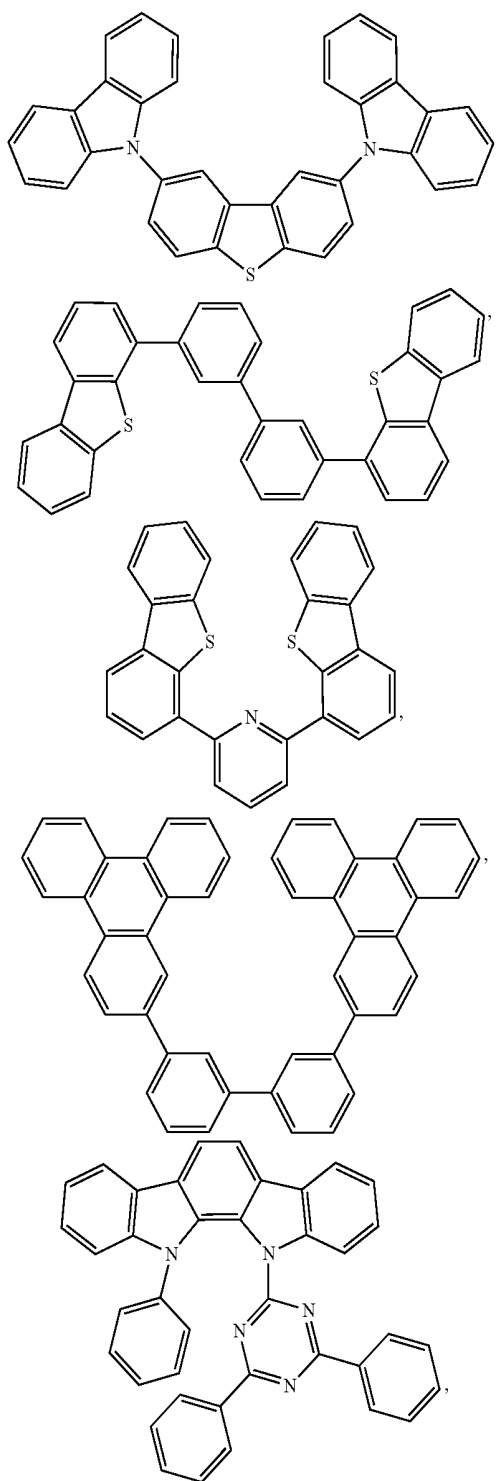

44

-continued

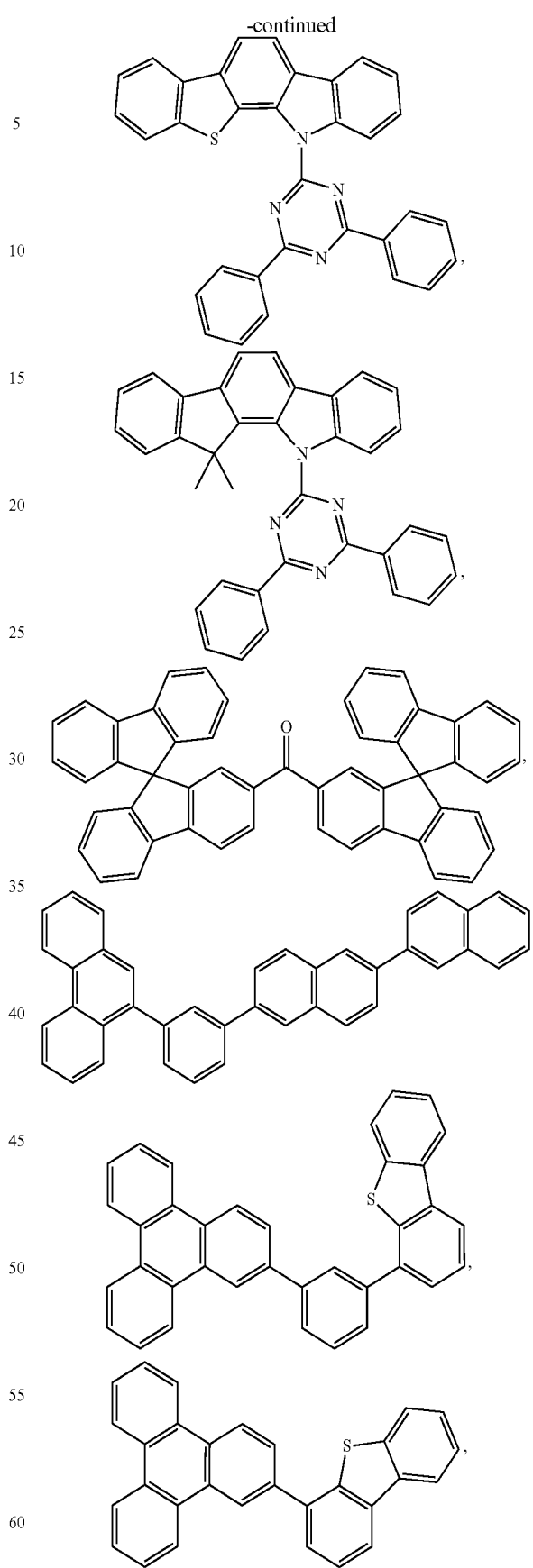

and combinations thereof.

65 In yet another aspect of the present disclosure, a method of forming a first device is described. The method can include providing a first electrode disposed on a substrate;

forming a first organic layer over the first electrode, where the first organic layer includes the first compound; and forming a second electrode disposed over the first organic layer. The first compound includes a first Ir moiety and a first Pt moiety, and any of the variations of such a compound (i.e., an Ir/Pt metal complex) as described herein.

In some embodiments, forming the first organic layer includes depositing the first compound by solution processing. In certain embodiments, the first compound can be sufficiently soluble in an organic solvent (e.g., toluene or THF) to permit deposition of the first compound by solution processing techniques. For example, the first compound may have a solubility of at least 0.01 g in 10 ml of an organic solvent. Examples of solution processing techniques include, but are not limited to, spin casting and ink jet printing.

In some embodiments, a second organic layer is formed over the first electrode such that the second organic layer is disposed between the first organic layer and the first electrode. In some embodiments, forming the second organic layer includes depositing the second organic layer by solution processing. In some embodiments, the method can include cross-linking the second organic layer. The second organic layer can be a hole injection material.

In some embodiments, the method can include forming a third organic layer over the second organic layer such that the third organic layer is disposed between the second organic layer and the first organic layer. The third organic layer can include a hole transport material. In some embodiments, forming the third organic layer can include depositing the third layer by solution processing. In some embodiments, the method can include cross-linking the third organic layer.

In some embodiments, the method can include depositing a fourth organic layer over the first organic layer such that the fourth organic layer is disposed between the first organic layer and the cathode. The fourth organic layer can include an electron transport material. In some embodiments, the fourth organic layer is deposited by vacuum thermal evaporation.

In some embodiments, the method can include depositing a fifth organic layer over the fourth organic layer such that the fifth organic layer is disposed between the fourth organic layer and the cathode. The fifth organic layer can include an electron transport material.

#### Combination with Other Materials

The materials described herein as useful for a particular layer in an organic light emitting device may be used in combination with a wide variety of other materials present in the device. For example, emissive dopants disclosed herein may be used in conjunction with a wide variety of hosts, transport layers, blocking layers, injection layers, electrodes and other layers that may be present. The materials described or referred to below are non-limiting examples of materials that may be useful in combination with the compounds disclosed herein, and one of skill in the art can readily consult the literature to identify other materials that may be useful in combination.

#### HIL/HTL:

A hole injecting/transporting material to be used in the present invention is not particularly limited, and any compound may be used as long as the compound is typically used as a hole injecting/transporting material. Examples of the material include, but not limit to: a phthalocyanine or porphyrin derivative; an aromatic amine derivative; an indolocarbazole derivative; a polymer containing fluorohydrocarbon; a polymer with conductivity dopants; a conducting

polymer, such as PEDOT/PSS; a self-assembly monomer derived from compounds such as phosphonic acid and silane derivatives; a metal oxide derivative, such as MoO<sub>3</sub>; a p-type semiconducting organic compound, such as 1,4,5,8,9,12-Hexaazatriphenylenehexacarbonitrile; a metal complex, and a cross-linkable compounds.

Examples of aromatic amine derivatives used in HIL or HTL include, but not limit to the following general structures:

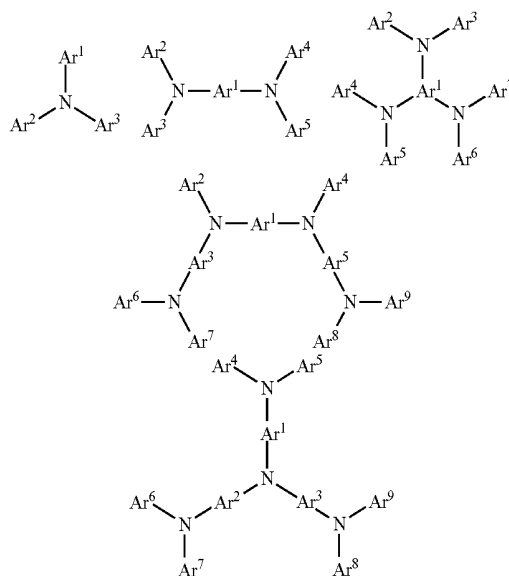

Each of Ar<sup>1</sup> to Ar<sup>9</sup> is selected from the group consisting aromatic hydrocarbon cyclic compounds such as benzene, biphenyl, triphenyl, triphenylene, naphthalene, anthracene, phenalene, phenanthrene, fluorene, pyrene, chrysene, perylene, azulene; group consisting aromatic heterocyclic compounds such as dibenzothiophene, dibenzofuran, dibenzoselenophene, furan, thiophene, benzofuran, benzothiophene, benzoselenophene, carbazole, indolocarbazole, pyridylindole, pyrrolodipyridine, pyrazole, imidazole, triazole, oxazole, thiazole, oxadiazole, oxatriazole, dioxazole, thiadiazole, pyridine, pyridazine, pyrimidine, pyrazine, triazine, oxazine, oxathiazine, oxadiazine, indole, benzimidazole, indazole, indoxazine, benzoxazole, benzisoxazole, benzothiazole, quinoline, isoquinoline, cinnoline, quinazoline, quinoxaline, naphthyridine, phthalazine, pteridine, xanthene, acridine, phenazine, phenothiazine, phenoxazine, benzofuropyridine, furodipyridine, benzothienopyridine, thienodipyridine, benzoselenophenopyridine, and selenophenodipyridine; and group consisting 2 to 10 cyclic structural units which are groups of the same type or different types selected from the aromatic hydrocarbon cyclic group and the aromatic heterocyclic group and are bonded to each other directly or via at least one of oxygen atom, nitrogen atom, sulfur atom, silicon atom, phosphorus atom, boron atom, chain structural unit and the aliphatic cyclic group. Wherein each Ar is further substituted by a substituent selected from the group consisting of hydrogen, deuterium, halide, alkyl, cycloalkyl, heteroalkyl, arylalkyl, alkoxy, aryloxy, amino, silyl, alkenyl, cycloalkenyl, heteroalkenyl, alkynyl, aryl, heteroaryl, acyl, carbonyl, carboxylic acids, ester, nitrile, isonitrile, sulfanyl, sulfinyl, sulfonyl, phosphino, and combinations thereof.

47

In one aspect, Ar<sup>1</sup> to Ar<sup>9</sup> is independently selected from the group consisting of:

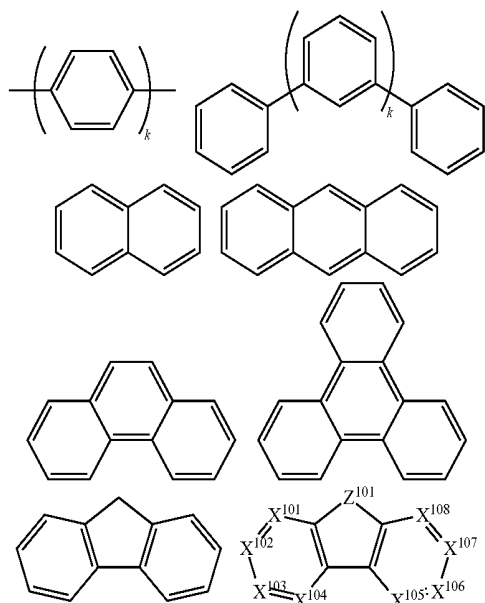

wherein k is an integer from 1 to 20; X<sup>101</sup> to X<sup>108</sup> is C (including CH) or N; Z<sup>101</sup> is NAr<sup>1</sup>, O or S; Ar<sup>1</sup> has the same group defined above.

Examples of metal complexes used in HIL or HTL include, but not limit to the following general formula:

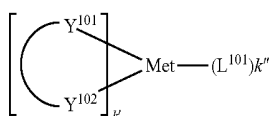

wherein Met is a metal, which can have an atomic weight greater than 40; (Y<sup>101</sup>-Y<sup>102</sup>) is a bidentate ligand, Y<sup>101</sup> and Y<sup>102</sup> are independently selected from C, N, O, P, and S; L<sup>101</sup> is an ancillary ligand; k' is an integer value from 1 to the maximum number of ligands that may be attached to the metal; and k'+k'' is the maximum number of ligands that may be attached to the metal.

In one aspect, (Y<sup>101</sup>-Y<sup>102</sup>) is a 2-phenylpyridine derivative. In another aspect, (Y<sup>101</sup>-Y<sup>102</sup>) is a carbene ligand. In another aspect, Met is selected from Ir, Pt, Os, and Zn. In a further aspect, the metal complex has a smallest oxidation potential in solution vs. Fc<sup>+</sup>/Fc couple less than about 0.6 V. Host:

The light emitting layer of the organic EL device of the present invention preferably contains at least a metal complex as light emitting material, and may contain a host material using the metal complex as a dopant material. Examples of the host material are not particularly limited, and any metal complexes or organic compounds may be used as long as the triplet energy of the host is larger than that of the dopant. While the Table below categorizes host materials as preferred for devices that emit various colors, any host material may be used with any dopant so long as the triplet criteria is satisfied.

Examples of metal complexes used as host are preferred to have the following general formula:

48

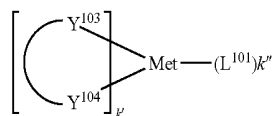

wherein Met is a metal; (Y<sup>103</sup>-Y<sup>104</sup>) is a bidentate ligand, Y<sup>103</sup> and Y<sup>104</sup> are independently selected from C, N, O, P, and S; L<sup>101</sup> is an another ligand; k' is an integer value from 1 to the maximum number of ligands that may be attached to the metal; and k'+k'' is the maximum number of ligands that may be attached to the metal.

In one aspect, the metal complexes are:

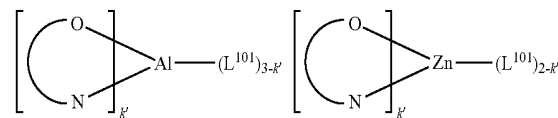

wherein (O—N) is a bidentate ligand, having metal coordinated to atoms O and N.

In another aspect, Met is selected from Ir and Pt. In a further aspect, (Y<sup>103</sup>-Y<sup>104</sup>) is a carbene ligand.

Examples of organic compounds used as host are selected from the group consisting aromatic hydrocarbon cyclic compounds such as benzene, biphenyl, triphenyl, triphenylene, naphthalene, anthracene, phenalene, phenanthrene, fluorene, pyrene, chrysene, perylene, azulene; group consisting aromatic heterocyclic compounds such as dibenzothiophene, dibenzofuran, dibenzoselenophene, furan, thiophene, benzofuran, benzothiophene, benzoselenophene, carbazole, indolocarbazole, pyridylindole, pyrrolodipyridine, pyrazole, imidazole, triazole, oxazole, thiazole, oxadiazole, oxatriazole, dioxazole, thiadiazole, pyridine, pyridazine, pyrimidine, pyrazine, triazine, oxazine, oxathiazine, oxadiazine, indole, benzimidazole, indazole, indoxazine, benzoxazole, benzisoxazole, benzothiazole, quinoline, isoquinoline, cinnoline, quinazoline, quinoxaline, naphthyridine, phthalazine, pteridine, xanthene, acridine, phenazine, phenothiazine, phenoxazine, benzofuropyridine, furodipyridine, benzothienopyridine, thienodipyridine, benzoselenophenopyridine, and selenophenodipyridine; and group consisting 2 to 10 cyclic structural units which are groups of the same type or different types selected from the aromatic hydrocarbon cyclic group and the aromatic heterocyclic group and are bonded to each other directly or via at least one of oxygen atom, nitrogen atom, sulfur atom, silicon atom, phosphorus atom, boron atom, chain structural unit and the aliphatic cyclic group. Wherein each group is further substituted by a substituent selected from the group consisting of hydrogen, deuterium, halide, alkyl, cycloalkyl, heteroalkyl, arylalkyl, alkoxy, aryloxy, amino, silyl, alkenyl, cycloalkenyl, heteroalkenyl, alkynyl, aryl, heteroaryl, acyl, carbonyl, carboxylic acids, ester, nitrile, isonitrile, sulfanyl, sulfinyl, sulfonyl, phosphino, and combinations thereof.

In one aspect, host compound contains at least one of the following groups in the molecule:

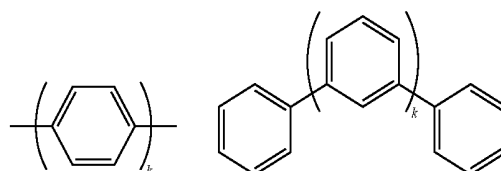

49

-continued

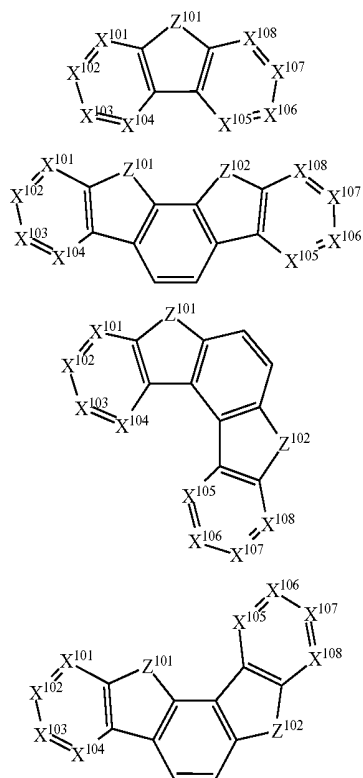
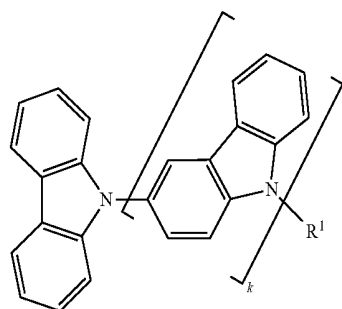
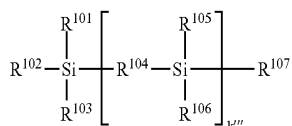
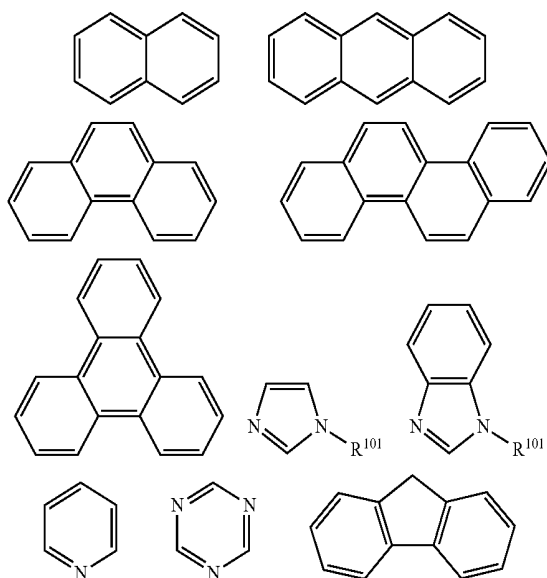

50

-continued

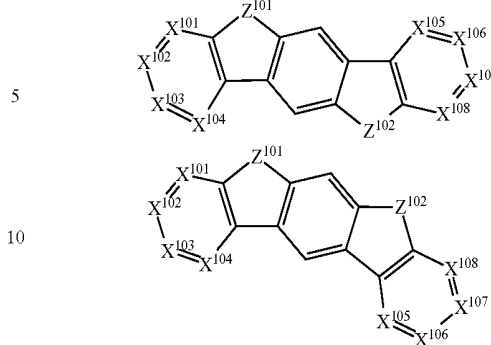

15 wherein  $R^{101}$  to  $R^{107}$  is independently selected from the group consisting of hydrogen, deuterium, halide, alkyl, cycloalkyl, heteroalkyl, arylalkyl, alkoxy, aryloxy, amino, silyl, alkenyl, cycloalkenyl, heteroalkenyl, alkynyl, aryl, heteroaryl, acyl, carbonyl, carboxylic acids, ester, nitrile, isonitrile, sulfanyl, sulfinyl, sulfonyl, phosphino, and combinations thereof, when it is aryl or heteroaryl, it has the similar definition as Ar's mentioned above.  $k$  is an integer from 0 to 20 or 1 to 20;  $k''$  is an integer from 0 to 20.  $X^{101}$  to  $X^{108}$  is selected from C (including CH) or N.  $Z^{101}$  and  $Z^{102}$  is selected from  $NR^{101}$ , O, or S.

HBL:

A hole blocking layer (HBL) may be used to reduce the number of holes and/or excitons that leave the emissive layer. The presence of such a blocking layer in a device may result in substantially higher efficiencies as compared to a similar device lacking a blocking layer. Also, a blocking layer may be used to confine emission to a desired region of an OLED.

In one aspect, compound used in HBL contains the same molecule or the same functional groups used as host described above.

In another aspect, compound used in HBL contains at least one of the following groups in the molecule:

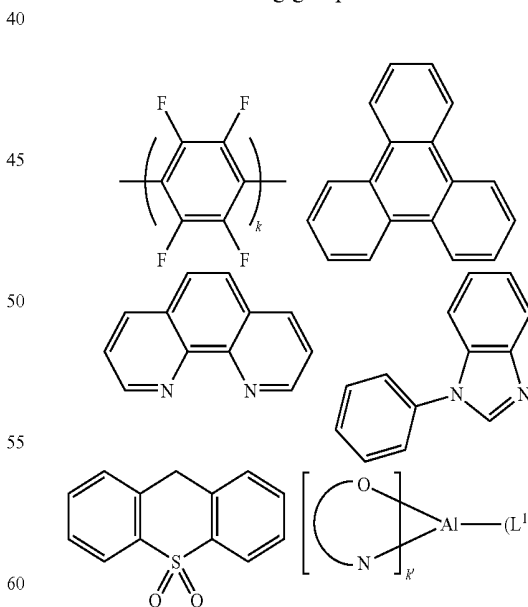

wherein  $k$  is an integer from 1 to 20;  $L^{101}$  is another ligand,  $k'$  is an integer from 1 to 3.

ETL:

Electron transport layer (ETL) may include a material capable of transporting electrons. Electron transport layer

51

may be intrinsic (undoped), or doped. Doping may be used to enhance conductivity. Examples of the ETL material are not particularly limited, and any metal complexes or organic compounds may be used as long as they are typically used to transport electrons.

In one aspect, compound used in ETL contains at least one of the following groups in the molecule:

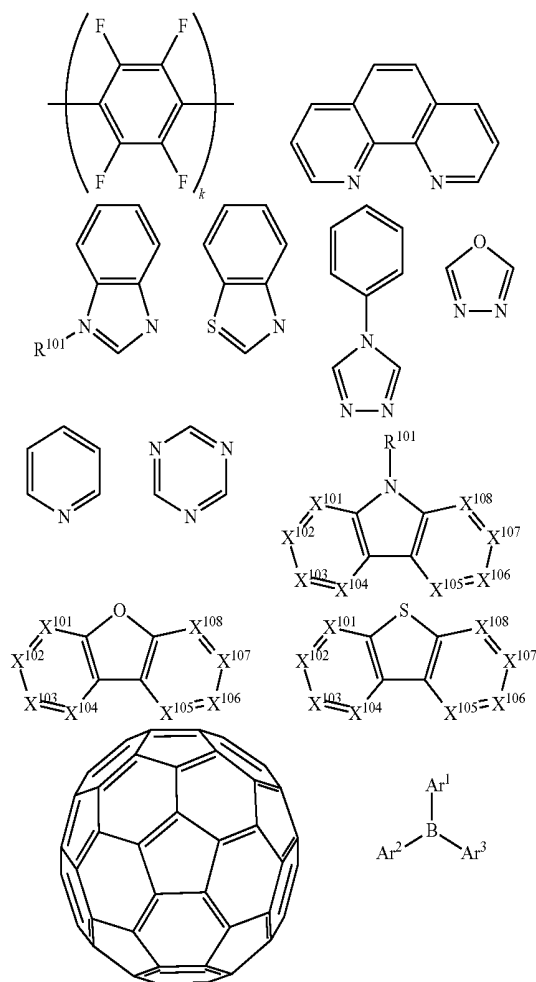

wherein  $R^{101}$  is selected from the group consisting of hydrogen, deuterium, halide, alkyl, cycloalkyl, heteroalkyl, aryl-

52

alkyl, alkoxy, aryloxy, amino, silyl, alkenyl, cycloalkenyl, heteroalkenyl, alkynyl, aryl, heteroaryl, acyl, carbonyl, carboxylic acids, ester, nitrile, isonitrile, sulfanyl, sulfinyl, sulfonyl, phosphino, and combinations thereof, when it is aryl or heteroaryl, it has the similar definition as Ar's mentioned above.  $Ar^1$  to  $Ar^3$  has the similar definition as Ar's mentioned above.  $k$  is an integer from 1 to 20.  $X^{101}$  to  $X^{108}$  is selected from C (including CH) or N.

In another aspect, the metal complexes used in ETL contains, but not limit to the following general formula:

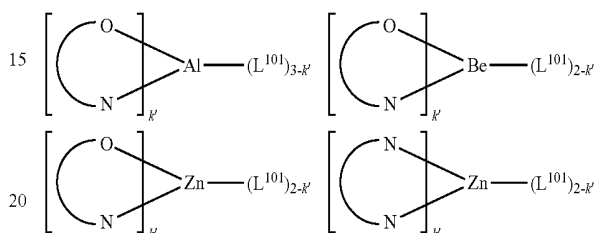

wherein (O—N) or (N—N) is a bidentate ligand, having metal coordinated to atoms O, N or N, N;  $L^{101}$  is another ligand;  $k'$  is an integer value from 1 to the maximum number of ligands that may be attached to the metal.

In any above-mentioned compounds used in each layer of the OLED device, the hydrogen atoms can be partially or fully deuterated. Thus, any specifically listed substituent, such as, without limitation, methyl, phenyl, pyridyl, etc. encompasses undeuterated, partially deuterated, and fully deuterated versions thereof. Similarly, classes of substituents such as, without limitation, alkyl, aryl, cycloalkyl, heteroaryl, etc. also encompass undeuterated, partially deuterated, and fully deuterated versions thereof.

In addition to and/or in combination with the materials disclosed herein, many hole injection materials, hole transporting materials, host materials, dopant materials, exciton/hole blocking layer materials, electron transporting and electron injecting materials may be used in an OLED. Non-limiting examples of the materials that may be used in an OLED in combination with materials disclosed herein are listed in Table 1 below. Table 1 lists non-limiting classes of materials, non-limiting examples of compounds for each class, and references that disclose the materials.

TABLE 1

MATERIAL	EXAMPLES OF MATERIAL	PUBLICATIONS
	Hole injection materials	

Phthalocyanine and porphyrin compounds

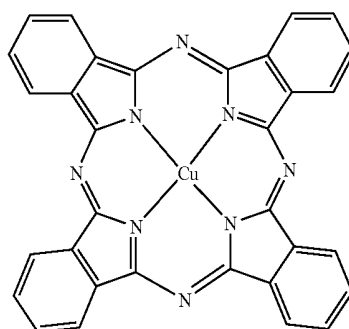

Appl. Phys. Lett.  
69, 2160 (1996)

TABLE 1-continued

MATERIAL	EXAMPLES OF MATERIAL	PUBLICATIONS
Starburst triarylaminines		J. Lumin. 72-74, 985 (1997)
CF <sub>x</sub> Fluorohydrocarbon polymer	$\text{---}[\text{CH}_x\text{F}_y]_n\text{---}$	Appl. Phys. Lett. 78, 673 (2001)
Conducting polymers (e.g., PEDOT:PSS, polyaniline, polythiophene)		Synth. Met. 87, 171 (1997) WO2007002683
Phosphonic acid and silane SAMs		US20030162053

TABLE 1-continued

MATERIAL	EXAMPLES OF MATERIAL	PUBLICATIONS
Triarylamine or polythiophene polymers with conductivity dopants		EP1725079A1
		
		
Organic compounds with conductive inorganic compounds, such as molybdenum and tungsten oxides	 <span data-bbox="1066 1641 1142 1659">+ MoO<sub>x</sub></span>	US20050123751 SID Symposium Digest, 37, 923 (2006)
		WO2009018009
n-type semiconducting organic complexes		US20020158242

TABLE 1-continued

MATERIAL	EXAMPLES OF MATERIAL	PUBLICATIONS
Metal organometallic complexes		US20060240279
Cross-linkable compounds		US20080220265
Polythiophene based polymers and copolymers		WO 2011075644 EP2350216
Hole transporting materials		
Triarylamines (e.g., TPD, $\alpha$ -NPD)		Appl. Phys. Lett. 51, 913 (1987)

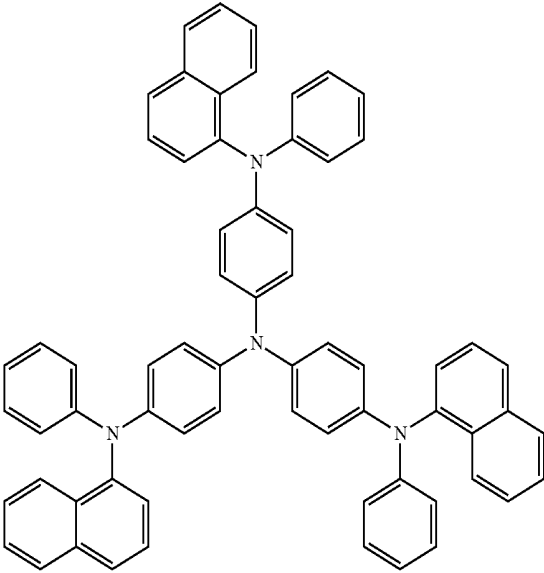
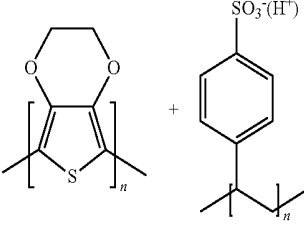
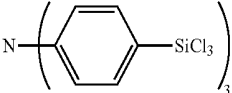
TABLE 1-continued

MATERIAL	EXAMPLES OF MATERIAL	PUBLICATIONS
		U.S. Pat. No. 5,061,569
		EP650955
		J. Mater. Chem. 3, 319 (1993)

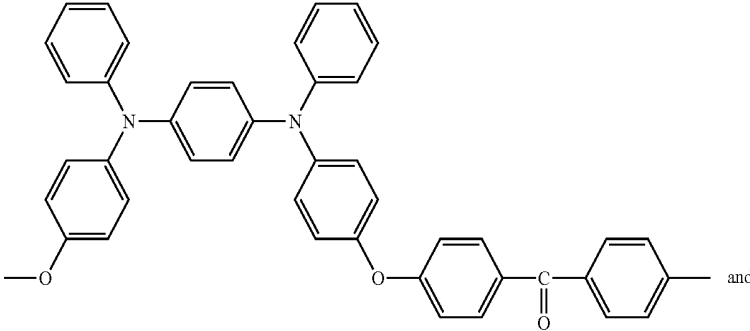
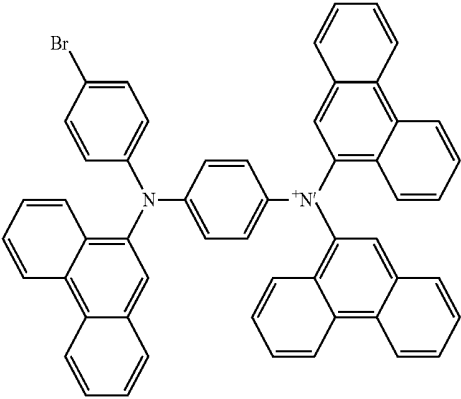
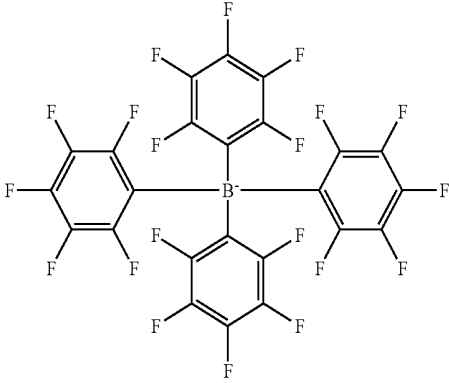
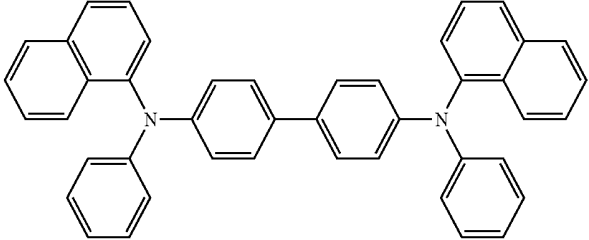
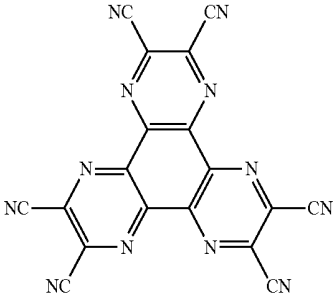
TABLE 1-continued

MATERIAL	EXAMPLES OF MATERIAL	PUBLICATIONS
		Appl. Phys. Lett. 90, 183503 (2007)
		Appl. Phys. Lett. 90, 183503 (2007)
Trialamine on spirofluorene core		Synth. Met. 91, 209 (1997)
Arylamine carbazole compounds		Adv. Mater. 6, 677 (1994), US20080124572

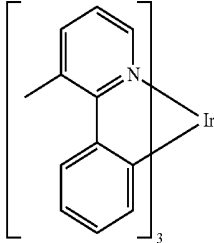
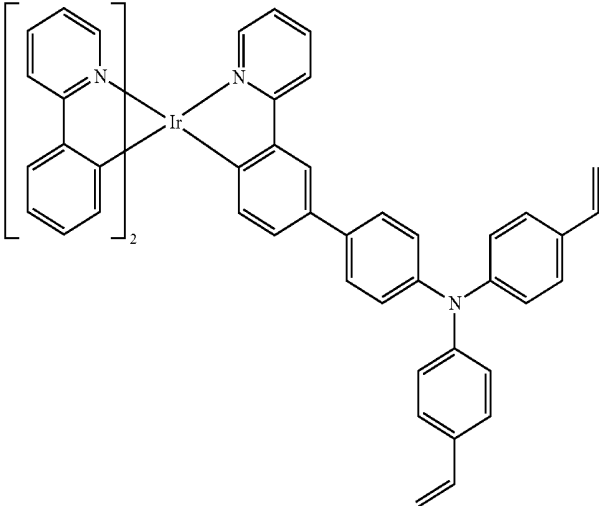
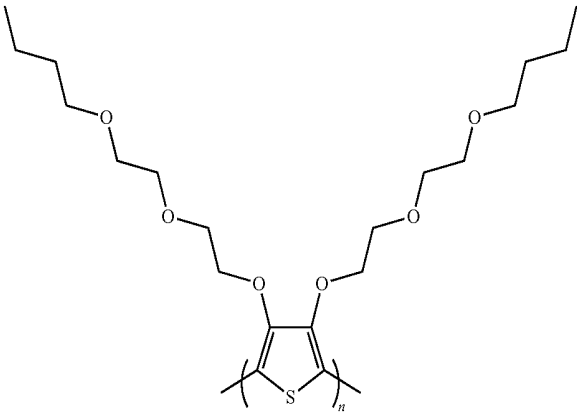
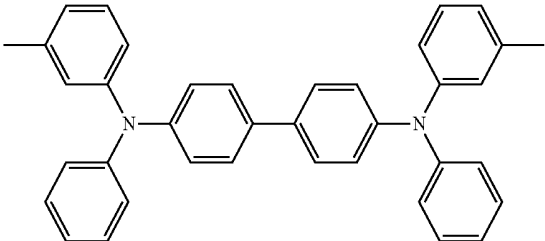
TABLE 1-continued

MATERIAL	EXAMPLES OF MATERIAL	PUBLICATIONS
Triarylamine with (di)benzothiophene/ (di)benzofuran		US20070278938, US20080106190 US20110163302
Indolocarbazoles		Synth. Met. 111, 421 (2000)
Isoindole compounds		Chem. Mater. 15, 3148 (2003)
Metal carbene complexes		US20080018221

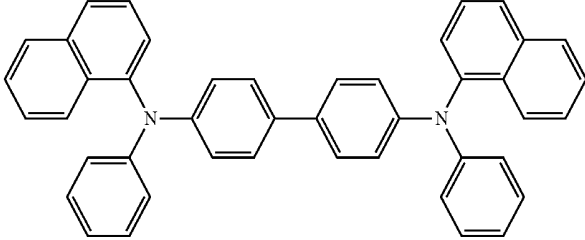
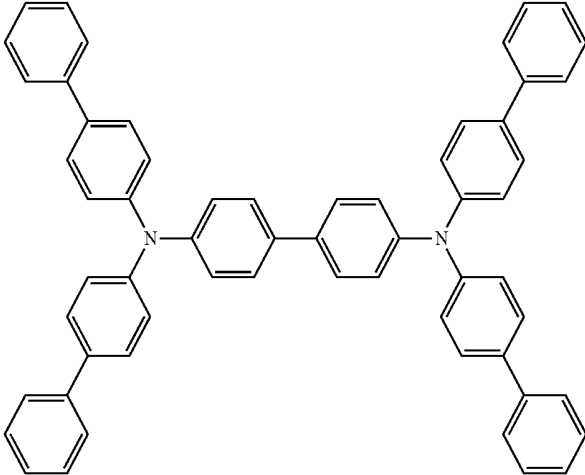
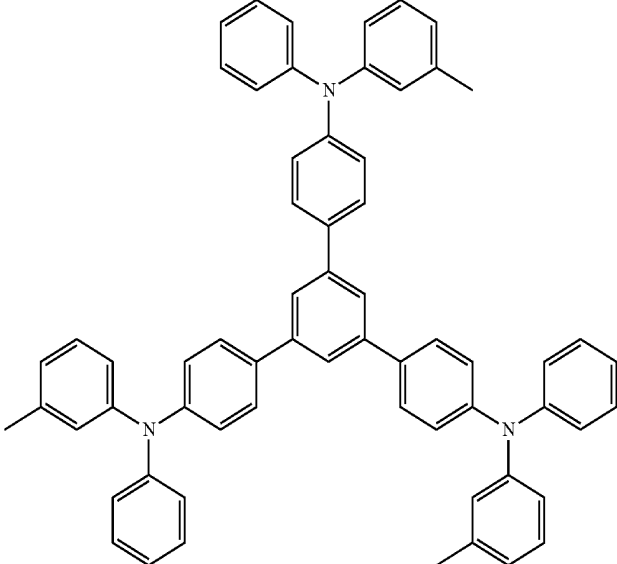
TABLE 1-continued

MATERIAL	EXAMPLES OF MATERIAL	PUBLICATIONS
Phosphorescent OLED host materials Red hosts		
Arylcarbazoles		Appl. Phys. Lett. 78, 1622 (2001)
Metal 8-hydroxyquinolates (e.g., Alq <sub>3</sub> , BALq)		Nature 395, 151 (1998)
		US20060202194
		WO2005014551
		WO2006072002
Metal phenoxybenzothiazole compounds		Appl. Phys. Lett. 90, 123509 (2007)
Conjugated oligomers and polymers (e.g., polyfluorene)		Org. Electron, 1, 15 (2000)

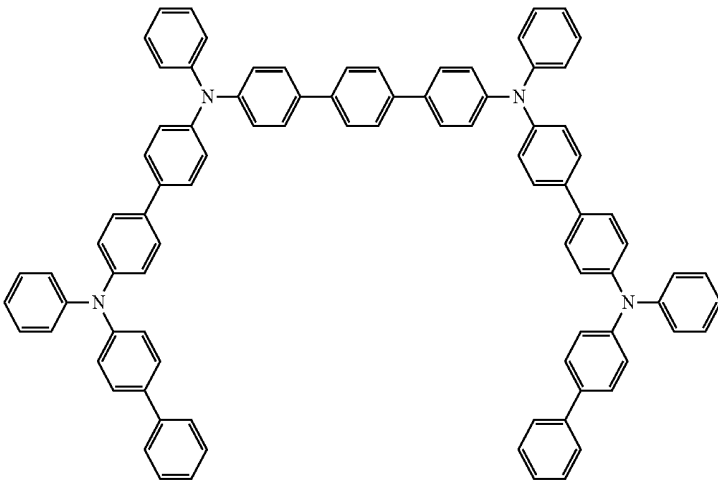
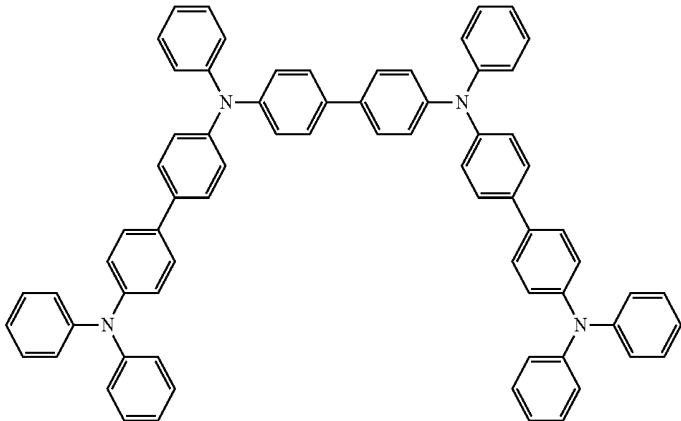
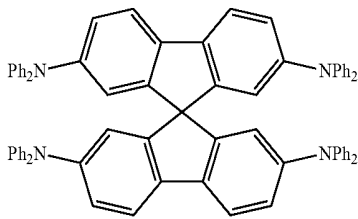
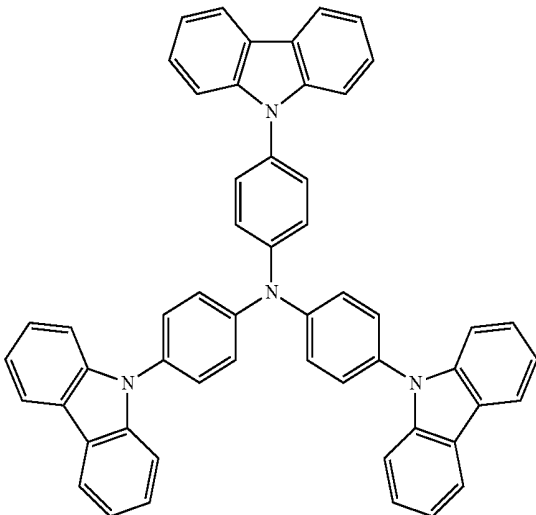

TABLE 1-continued

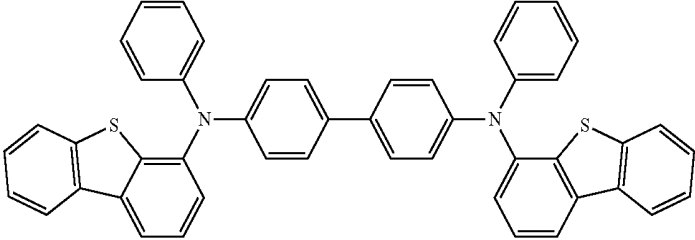
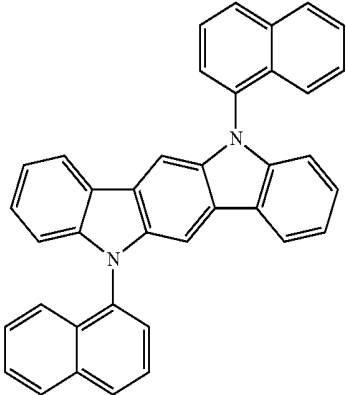
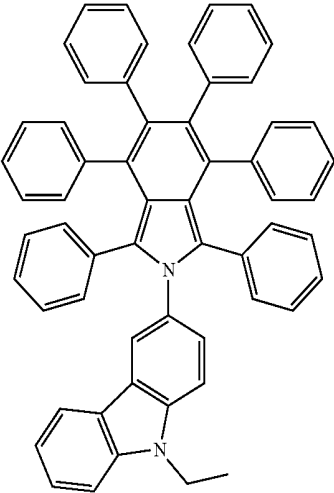
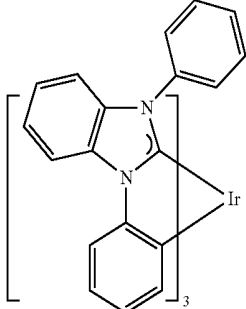
MATERIAL	EXAMPLES OF MATERIAL	PUBLICATIONS
Aryltriphenylene compounds		US20060280965
		US20060280965
		WO2009021126
Poly-fused heteroaryl compounds		US20090309488 US20090302743 US20100012931
Donor acceptor type molecules		WO2008056746

TABLE 1-continued

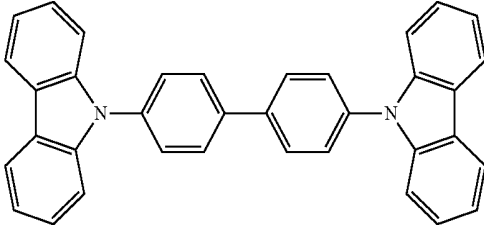
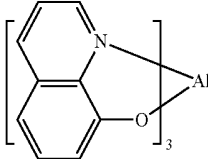
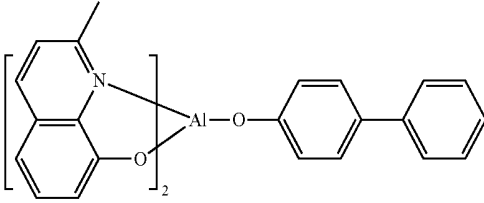
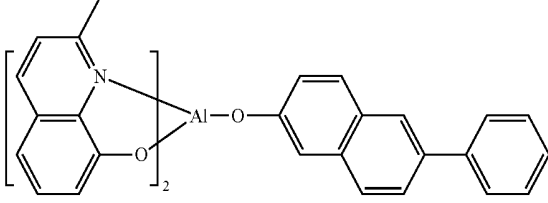
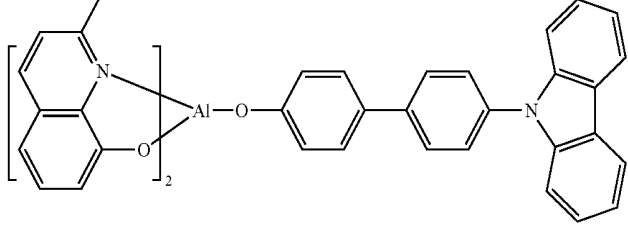
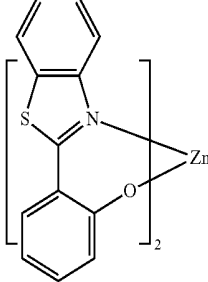
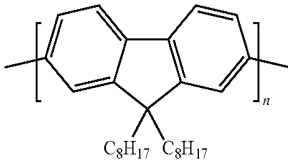
MATERIAL	EXAMPLES OF MATERIAL	PUBLICATIONS
Aza-carbazole/DBT/DBF		WO2010107244
Polymers (e.g., PVK)		JP2008074939
Spirofluorene compounds		US20100187984
		Appl. Phys. Lett. 77, 2280 (2000)
		WO2004093207

TABLE 1-continued

MATERIAL	EXAMPLES OF MATERIAL	PUBLICATIONS
Metal phenoxybenzoxazole compounds		WO2005089025
		WO2006132173
		JP200511610
Spirofluorene-carbazole compounds		JP2007254297
		JP2007254297

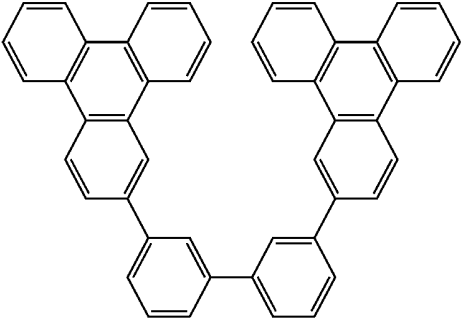
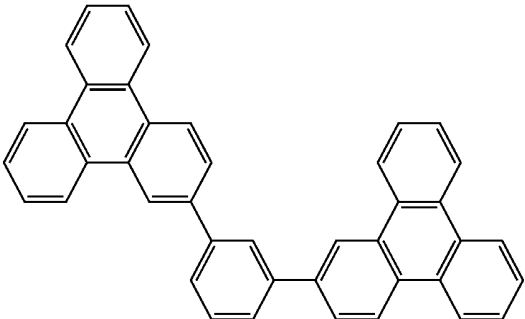
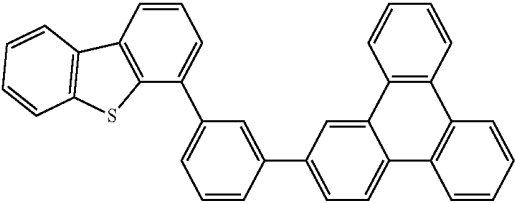
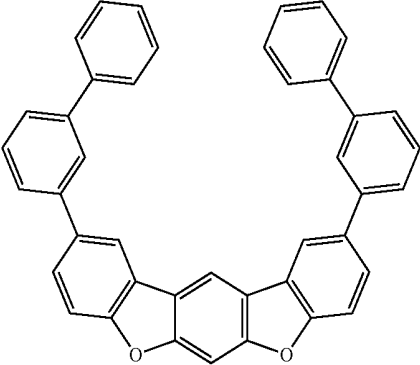
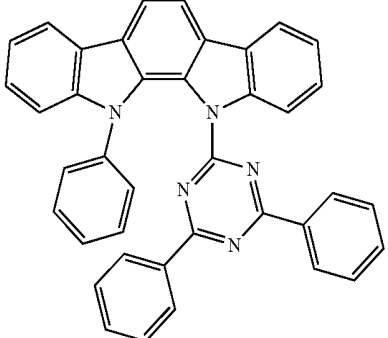
TABLE 1-continued

MATERIAL	EXAMPLES OF MATERIAL	PUBLICATIONS
Indolocabazoles		WO2007063796
		WO2007063754
5-member ring electron deficient heterocycles (e.g., triazole, oxadiazole)		J. Appl. Phys. 90, 5048 (2001)
		WO2004107822
Tetraphenylene complexes		US20050112407

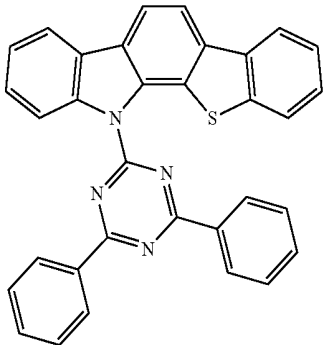
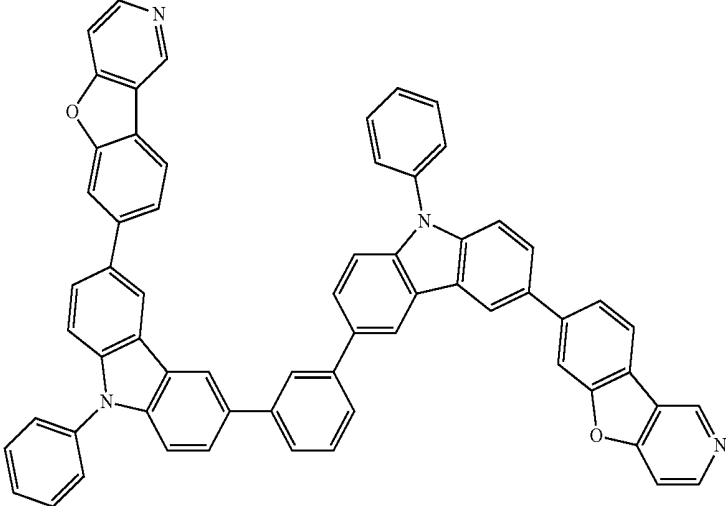
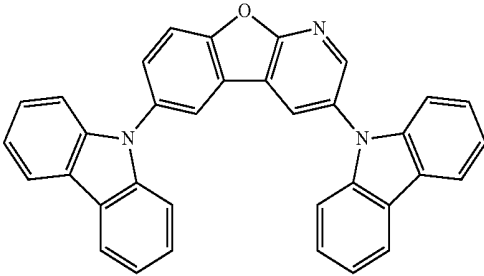
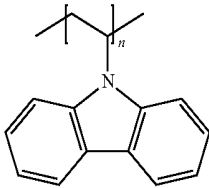
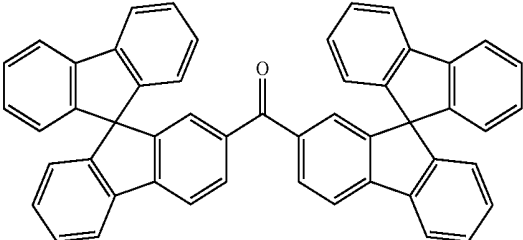
TABLE 1-continued

MATERIAL	EXAMPLES OF MATERIAL	PUBLICATIONS
Metal phenoxypyridine compounds		WO2005030900
Metal coordination complexes (e.g., Zn, Al with N-N ligands)	 <p data-bbox="735 891 815 909">Blue hosts</p>	US20040137268, US20040137267
Arylcarbazoles		Appl. Phys. Lett, 82, 2422 (2003)
		US20070190359
Dibenzothiophene/ Dibenzofuran- carbazole compounds		WO2006114966, US20090167162
		US20090167162

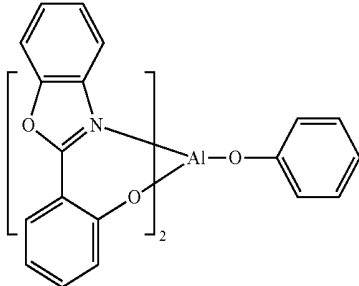
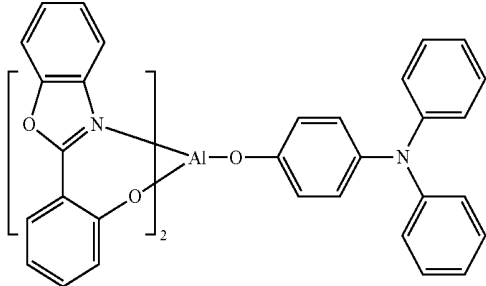
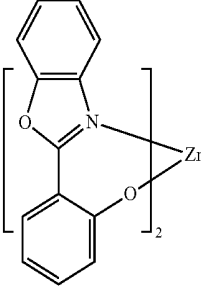
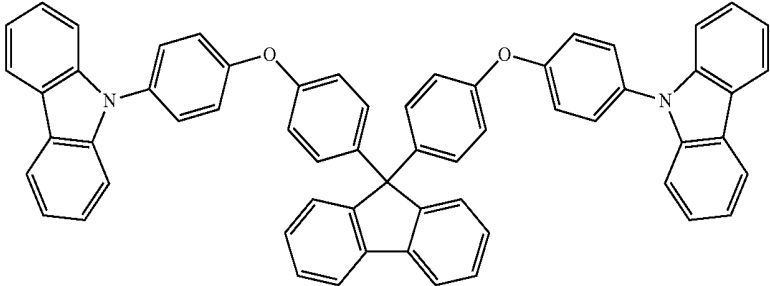
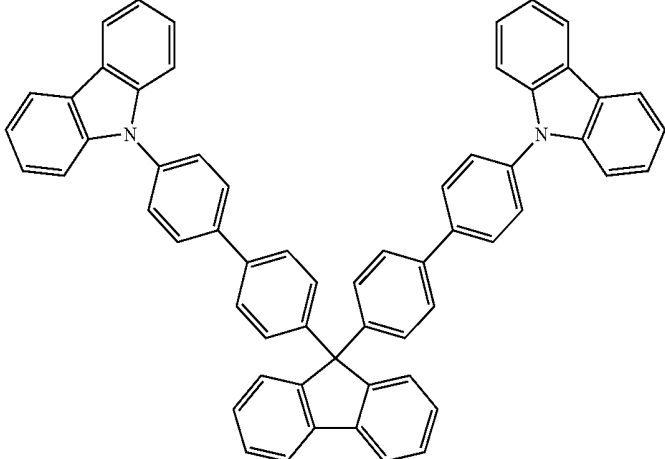
TABLE 1-continued

MATERIAL	EXAMPLES OF MATERIAL	PUBLICATIONS
		WO2009086028
		US20090030202, US20090017330
		US20100084966
Silicon aryl compounds		US20050238919
		WO2009003898

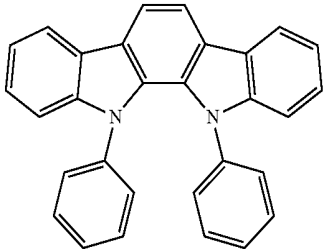
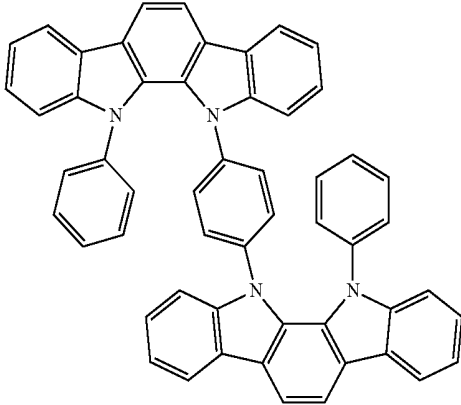
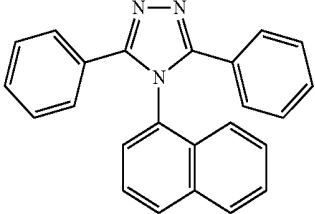
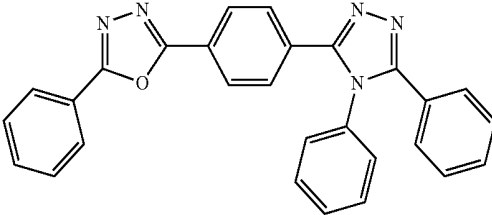
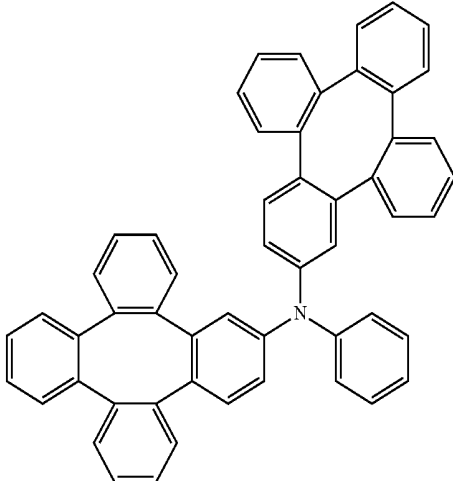
TABLE 1-continued

MATERIAL	EXAMPLES OF MATERIAL	PUBLICATIONS
Silicon/Germanium aryl compounds		EP2034538A
Aryl benzoyl ester		WO2006100298
Carbazole linked by non-conjugated groups		US20040115476
Aza-carbazoles		US20060121308
High triplet metal organometallic complex		U.S. Pat. No. 7,154,114

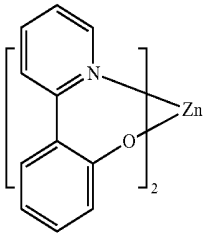
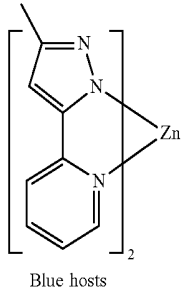
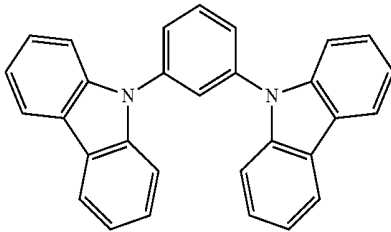
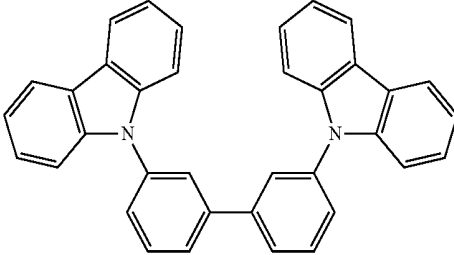
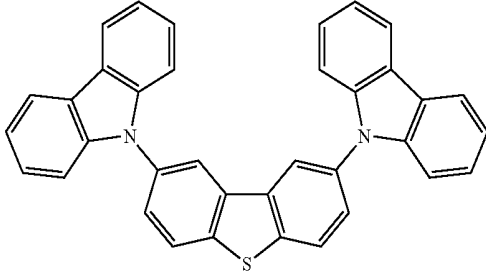
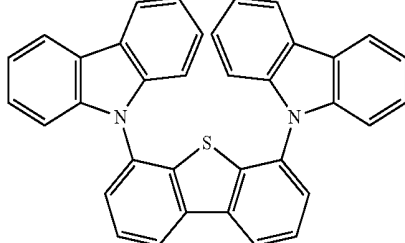
TABLE 1-continued

MATERIAL	EXAMPLES OF MATERIAL	PUBLICATIONS
Heavy metal porphyrins (e.g., PtOEP)	<p style="text-align: center;">Phosphorescent dopants Red dopants</p> 	Nature 395, 151 (1998)
Iridium(III) organometallic complexes		Appl. Phys. Lett. 78, 1622 (2001)
		US2006835469
		US2006835469
		US20060202194

TABLE 1-continued

MATERIAL	EXAMPLES OF MATERIAL	PUBLICATIONS
		US20060202194
		US20070087321
		US20080261076 US20100090591
		US20070087321
	 <p data-bbox="778 2018 826 2042"><math>H_{17}C_8</math></p>	Adv. Mater. 19, 739 (2007)

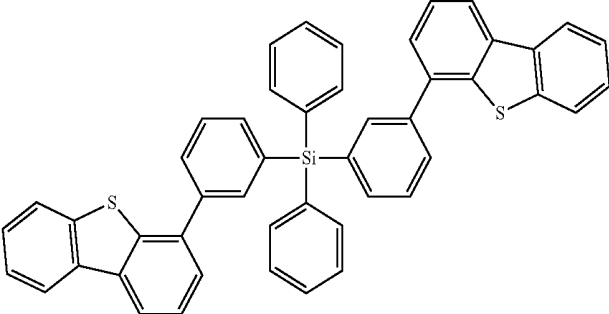
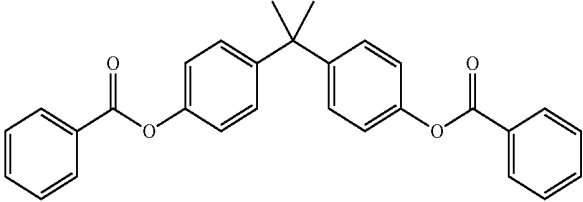
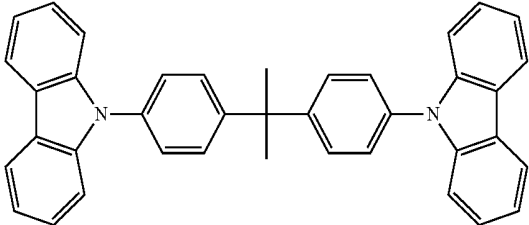
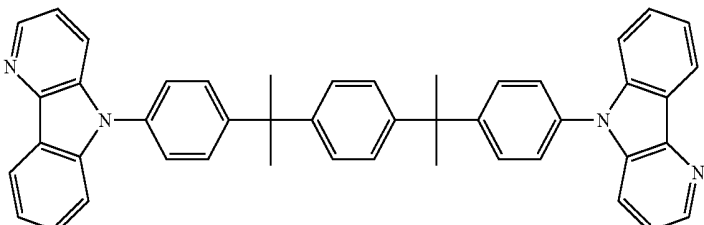
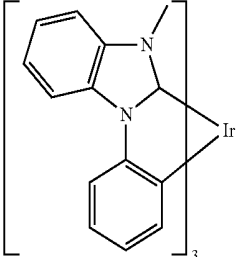
TABLE 1-continued

MATERIAL	EXAMPLES OF MATERIAL	PUBLICATIONS
----------	----------------------	--------------

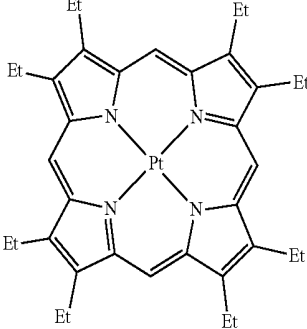
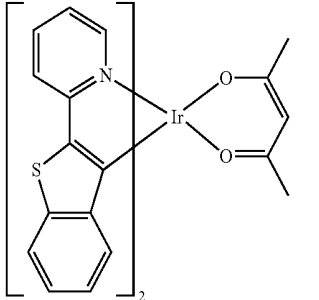
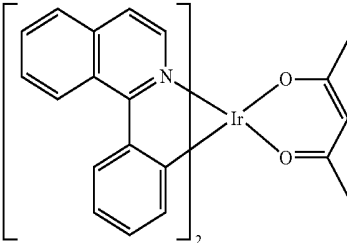
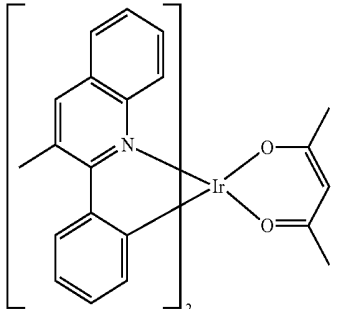
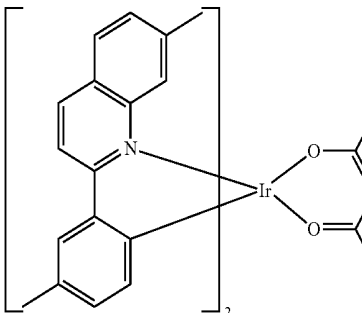

WO2009100991

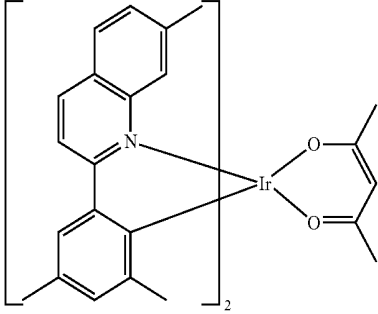
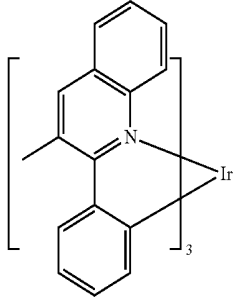
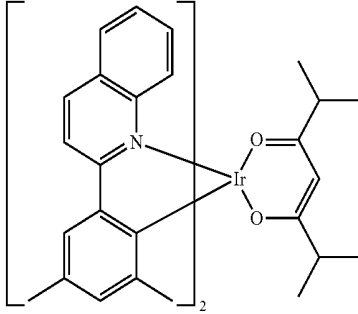
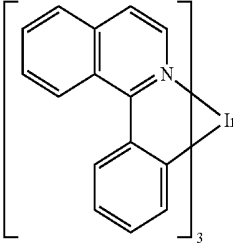
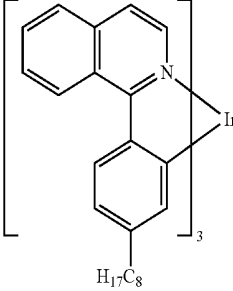
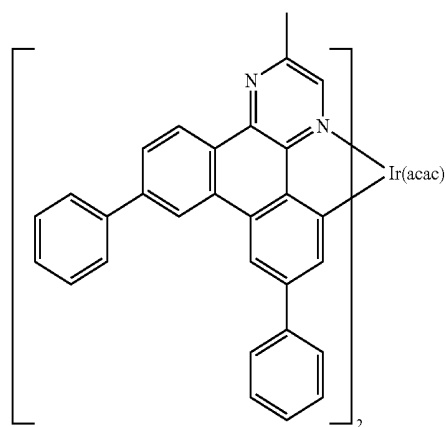
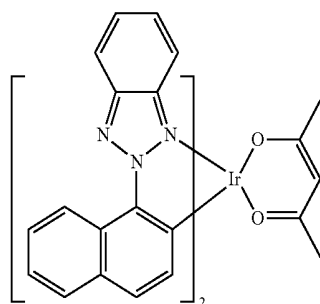

WO2008101842

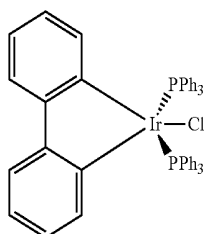
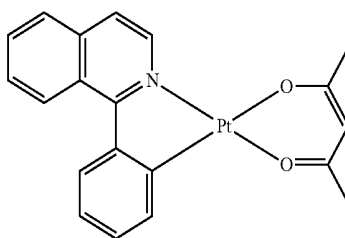
U.S. Pat. No.  
7,232,618Platinum(II)  
organometallic  
complexes

WO2003040257

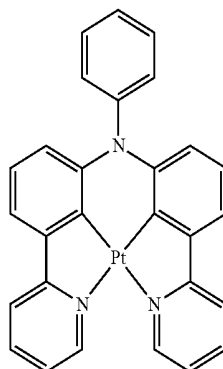

US20070103060

TABLE 1-continued

MATERIAL	EXAMPLES OF MATERIAL	PUBLICATIONS
Osmium(III) complexes		Chem. Mater. 17, 3532 (2005)
Ruthenium(II) complexes		Adv. Mater. 17, 1059 (2005)
Rhenium (I), (II), and (III) complexes		US20050244673
Green dopants		
Iridium(III) organometallic complexes		Inorg. Chem. 40, 1704 (2001)
and its derivatives		
		US20020034656

TABLE 1-continued

MATERIAL	EXAMPLES OF MATERIAL	PUBLICATIONS
		U.S. Pat. No. 7,332,232
		US20090108737
		WO2010028151

TABLE 1-continued

MATERIAL	EXAMPLES OF MATERIAL	PUBLICATIONS
	<p>The structure shows an Iridium (Ir) center coordinated to two phenylpyridine ligands (each in brackets with a subscript 2) and one phenylpyrazole ligand. The phenylpyridine ligands consist of a phenyl ring fused to a pyridine ring. The phenylpyrazole ligand consists of a phenyl ring fused to a pyrazole ring.</p>	EP1841834B
	<p>The structure shows an Iridium (Ir) center coordinated to three phenylquinoline ligands, each enclosed in brackets with a subscript 3. Each phenylquinoline ligand consists of a phenyl ring fused to a quinoline ring.</p>	US20060127696
	<p>The structure shows an Iridium (Ir) center coordinated to three phenylisoquinoline ligands, each enclosed in brackets with a subscript 3. Each phenylisoquinoline ligand consists of a phenyl ring fused to an isoquinoline ring.</p>	US20090039776
	<p>The structure shows an Iridium (Ir) center coordinated to three phenylbenzothienopyridine ligands, each enclosed in brackets with a subscript 3. Each ligand consists of a phenyl ring fused to a benzothienopyridine ring system.</p>	U.S. Pat. No. 6,921,915
	<p>The structure shows an Iridium (Ir) center coordinated to two phenylpyridine ligands (each in brackets with a subscript 2) and one phenylbenzothienopyridine ligand. The phenylpyridine ligands consist of a phenyl ring fused to a pyridine ring. The phenylbenzothienopyridine ligand consists of a phenyl ring fused to a benzothienopyridine ring system.</p>	US20100244004

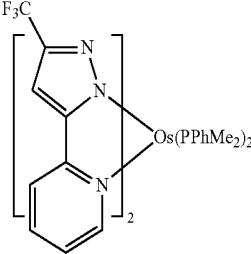
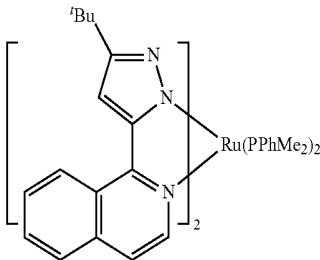
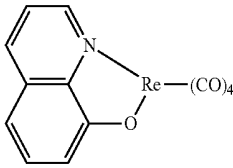
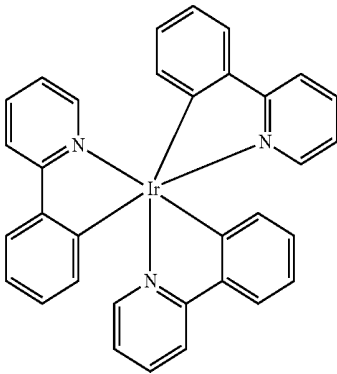
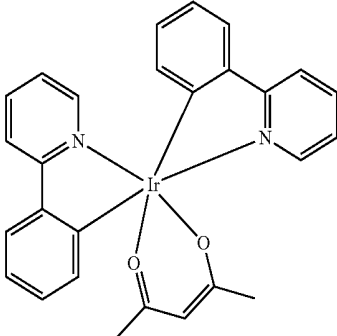
TABLE 1-continued

MATERIAL	EXAMPLES OF MATERIAL	PUBLICATIONS
		U.S. Pat. No. 6,687,266
		Chem. Mater. 16, 2480 (2004)
		US20070190359
		US 20060008670 JP2007123392
		WO2010086089, WO2011044988
		Adv. Mater. 16, 2003 (2004)

TABLE 1-continued

MATERIAL	EXAMPLES OF MATERIAL	PUBLICATIONS
	<p>The structure shows an Ir atom coordinated to three ligands: a phenylpyridine ligand (a benzene ring fused to a pyridine ring), a benzimidazole ligand (two benzene rings fused to a five-membered imidazole ring), and a phenyl group. The Ir atom is also coordinated to a third ligand, indicated by a triangle.</p>	Angew. Chem. Int. Ed. 2006, 45, 7800
	<p>The structure shows an Ir atom coordinated to three ligands: a benzothiazole ligand (a benzene ring fused to a five-membered thiazole ring), and two other ligands indicated by triangles.</p>	WO2009050290
	<p>The structure shows an Ir atom coordinated to three ligands: a benzothiazole ligand (a benzene ring fused to a five-membered thiazole ring), and two other ligands indicated by triangles.</p>	US20090165846
	<p>The structure shows an Ir atom coordinated to three ligands: a benzimidazole ligand (two benzene rings fused to a five-membered imidazole ring), and two other ligands indicated by triangles. One of the triangles is part of a cyclic ligand containing oxygen and sulfur atoms.</p>	US20080015355
	<p>The structure shows an Ir atom coordinated to three ligands: two pyridine rings and one other ligand indicated by a triangle. The complex is associated with a <math>(PF_6)_3</math> counterion.</p>	US20010015432
	<p>The structure shows an Ir atom coordinated to three ligands: a pyridine ring, a boron-containing ligand (a benzene ring fused to a five-membered ring containing a boron atom and a nitrogen atom), and one other ligand indicated by a triangle.</p>	US20100295032

TABLE 1-continued

MATERIAL	EXAMPLES OF MATERIAL	PUBLICATIONS
Monomer for polymeric metal organometallic compounds		U.S. Pat. No. 7,250,226, U.S. Pat. No. 7,396,598
Pt(II) organometallic complexes, including polydentate ligands		Appl. Phys. Lett. 86, 153505 (2005)
		Appl. Phys. Lett. 86, 153505 (2005)
		Chem. Lett. 34, 592 (2005)
		WO2002015645

TABLE 1-continued

MATERIAL	EXAMPLES OF MATERIAL	PUBLICATIONS
		US20060263635
		US20060182992 US20070103060
Cu complexes		WO2009000673
		US20070111026

TABLE 1-continued

MATERIAL	EXAMPLES OF MATERIAL	PUBLICATIONS
Gold complexes		Chem. Commun. 2906 (2005)
Rhenium(III) complexes		Inorg. Chem. 42, 1248 (2003)
Osmium(II) complexes		U.S. Pat. No. 7,279,704
Deuterated organometallic complexes		US20030138657

TABLE 1-continued

MATERIAL	EXAMPLES OF MATERIAL	PUBLICATIONS
Organometallic complexes with two or more metal centers		US20030152802
		U.S. Pat. No. 7,090,928
	Blue dopants	
Iridium(III) organometallic complexes		WO2002002714
		WO2006009024
		US20060251923 US20110057559 US20110204333

TABLE 1-continued

MATERIAL	EXAMPLES OF MATERIAL	PUBLICATIONS
		U.S. Pat. No. 7,393,599, WO2006056418, US20050260441, WO2005019373
		U.S. Pat. No. 7,534,505
		WO2011051404
		U.S. Pat. No. 7,445,855
		US20070190359, US20080297033, US20100148663

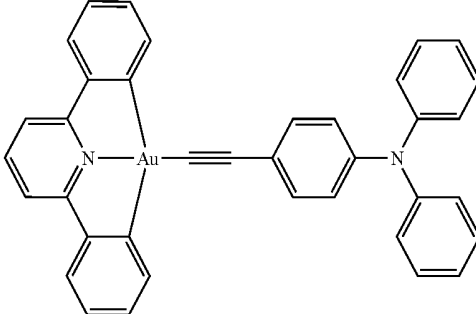
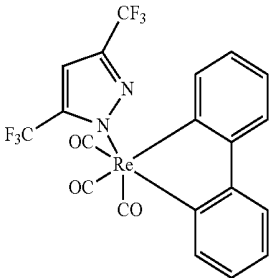
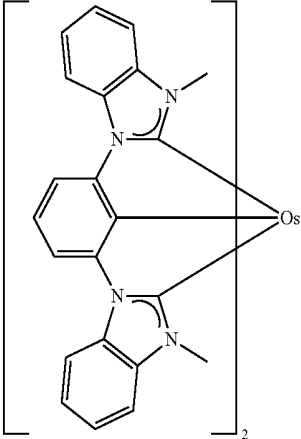
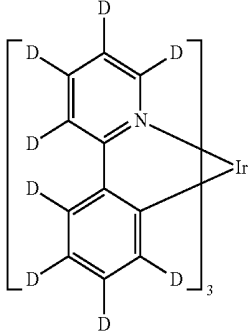
TABLE 1-continued

MATERIAL	EXAMPLES OF MATERIAL	PUBLICATIONS
		U.S. Pat. No. 7,338,722
		US20020134984
		Angew. Chem. Int. Ed. 47, 4542 (2008)
		Chem. Mater. 18, 5119 (2006)
		Inorg. Chem. 46, 4308 (2007)

TABLE 1-continued

MATERIAL	EXAMPLES OF MATERIAL	PUBLICATIONS
		WO2005123873
		WO2005123873
		WO2007004380
		WO2006082742
Osmium(II) complexes		U.S. Pat. No. 7,279,704

TABLE 1-continued

MATERIAL	EXAMPLES OF MATERIAL	PUBLICATIONS
Gold complexes		Organometallics 23, 3745 (2004)
Platinum(II) complexes		Appl. Phys. Lett. 74, 1361 (1999)
Pt tetradentate complexes with at least one metal-carbene bond		WO2006098120, WO2006103874
Exciton/hole blocking layer materials		
Bathocuprine compounds (e.g., BCP, BPhen)		U.S. Pat. No. 7,655,323
Bathocuprine compounds (e.g., BCP, BPhen)		Appl. Phys. Lett. 75, 4 (1999)
Bathocuprine compounds (e.g., BCP, BPhen)		Appl. Phys. Lett. 79, 449 (2001)
Metal 8-hydroxyquinolates (e.g., BAlq)		Appl. Phys. Lett. 81, 162 (2002)

TABLE 1-continued

MATERIAL	EXAMPLES OF MATERIAL	PUBLICATIONS
5-member ring electron deficient heterocycles such as triazole, oxadiazole, imidazole, benzoimidazole	 A central benzene ring is substituted at the 1, 3, and 5 positions with triazole rings. The triazole at the 1-position is a 1-phenyl-1H-1,2,3-triazole. The triazole at the 3-position is a 1-phenyl-1H-1,2,3-triazole. The triazole at the 5-position is a 1-phenyl-1H-1,2,3-triazole.	Appl. Phys. Lett. 81, 162 (2002)
Triphenylene compounds	 A central triphenylene core is substituted at the 1, 3, 6, and 8 positions with phenyl rings. The phenyl rings are attached to the 1, 3, 6, and 8 positions of the triphenylene core.	US20050025993
Fluorinated aromatic compounds	 A central biphenyl core is substituted at the 2, 2', 3, 3', 4, 4', 5, 5', 6, 6' positions with fluorine atoms. The fluorine atoms are attached to the 2, 2', 3, 3', 4, 4', 5, 5', 6, 6' positions of the biphenyl core.	Appl. Phys. Lett. 79, 156 (2001)

TABLE 1-continued

MATERIAL	EXAMPLES OF MATERIAL	PUBLICATIONS
Phenothiazine-S-oxide		WO2008132085
Silylated five-membered nitrogen, oxygen, sulfur or phosphorus dibenzoheterocycles		WO2010079051
Aza-carbazoles		US20060121308
Electron transporting materials		
Anthracene-benzimidazole compounds		WO2003060956
		US20090179554

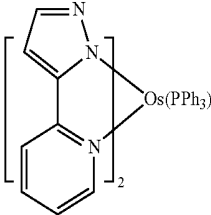
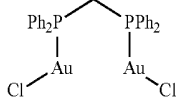
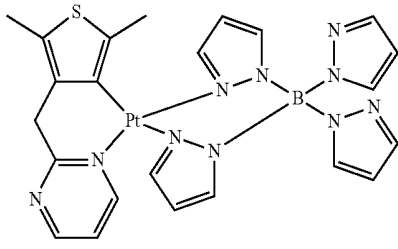
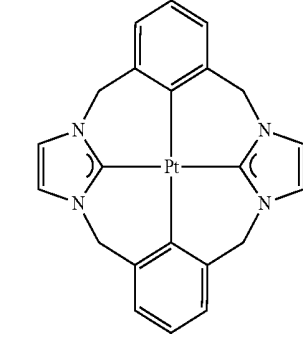
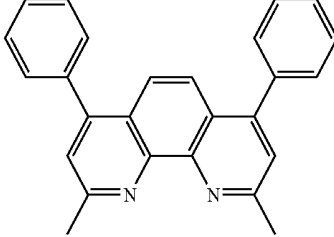
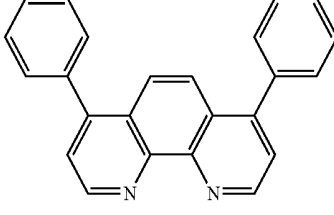
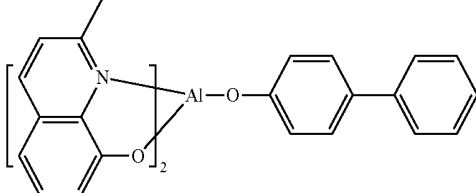
TABLE 1-continued

MATERIAL	EXAMPLES OF MATERIAL	PUBLICATIONS
Aza triphenylene derivatives		US20090115316
Anthracene-benzothiazole compounds		Appl. Phys. Lett. 89, 063504 (2006)
Metal 8-hydroxyquinolates (e.g., Alq <sub>3</sub> , Zrq <sub>4</sub> )		Appl. Phys. Lett. 51, 913 (1987) U.S. Pat. No. 7,230,107
Metal hydroxybenzoquinolates		Chem. Lett. 5, 905 (1993)
Bathocuprine compounds such as BCP, BPhen, etc		Appl. Phys. Lett. 91, 263503 (2007)
		Appl. Phys. Lett. 79, 449 (2001)

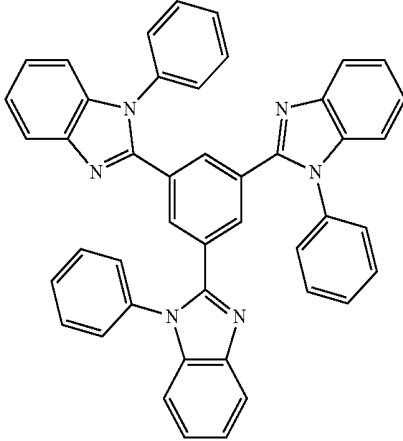
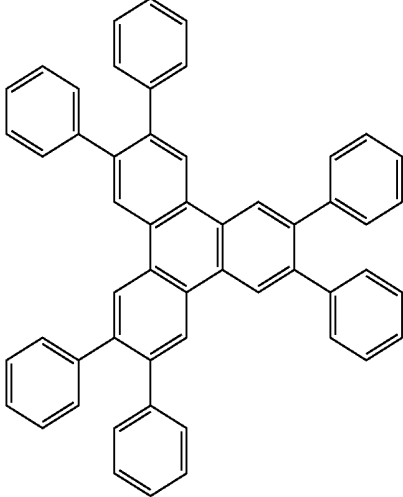
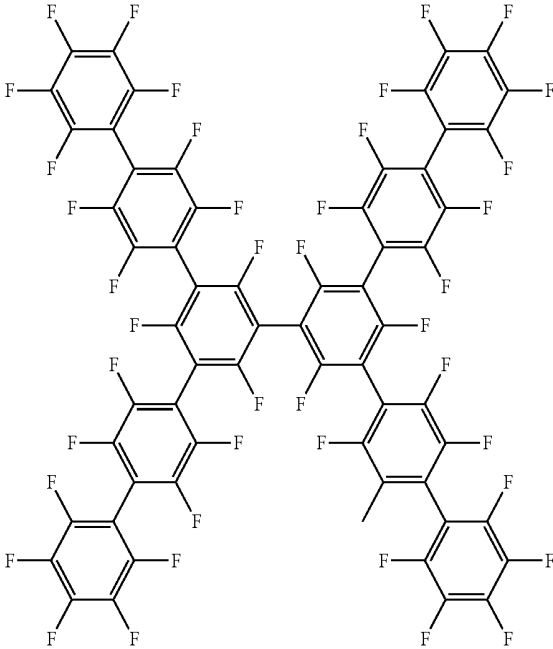
TABLE 1-continued

MATERIAL	EXAMPLES OF MATERIAL	PUBLICATIONS
5-member ring electron deficient heterocycles (e.g., triazole, oxadiazole, imidazole, benzoimidazole)		Appl. Phys. Lett. 74, 865 (1999)
		Appl. Phys. Lett. 55, 1489 (1989)
		Jpn. J. Apply. Phys. 32, L917 (1993)
Silole compounds		Org. Electron. 4, 113 (2003)
Arylborane compounds		J. Am. Chem. Soc. 120, 9714 (1998)
Fluorinated aromatic compounds		J. Am. Chem. Soc. 122, 1832 (2000)

TABLE 1-continued

MATERIAL	EXAMPLES OF MATERIAL	PUBLICATIONS
Fullerene (e.g., C <sub>60</sub> )		US20090101870
Triazine complexes		US20040036077
Zn (N <sup>^</sup> N) complexes		U.S. Pat. No. 6,528,187

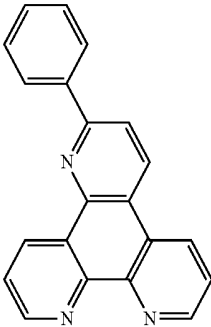
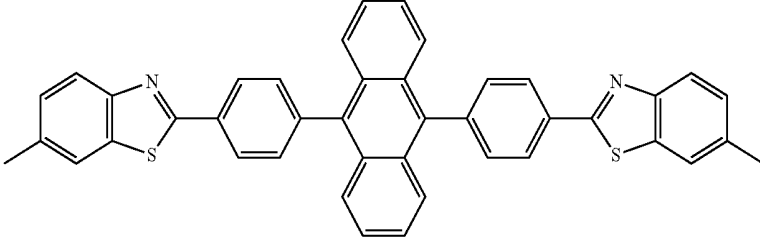
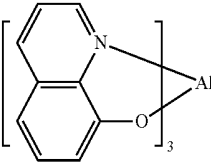
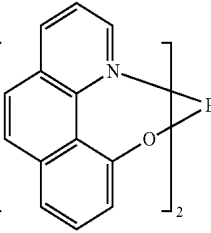
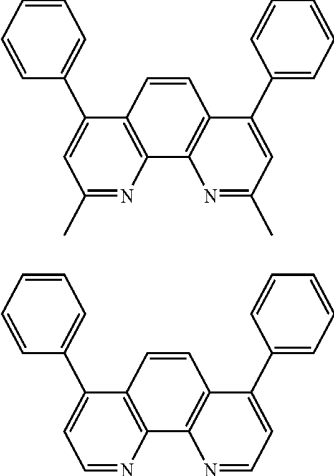
## EXPERIMENTAL

DFT calculations were performed for certain example compounds and comparative compounds. The results are

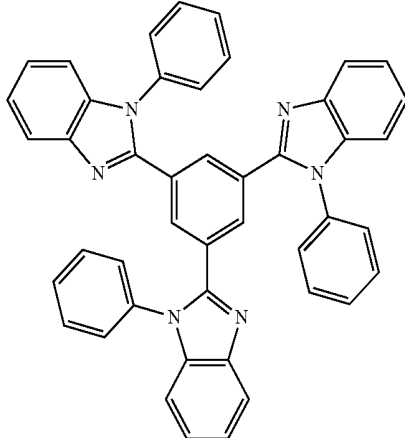
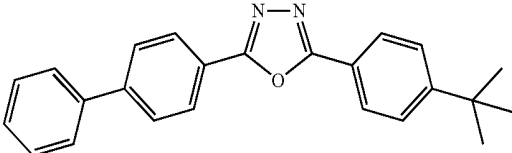
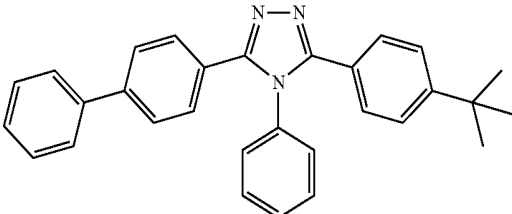
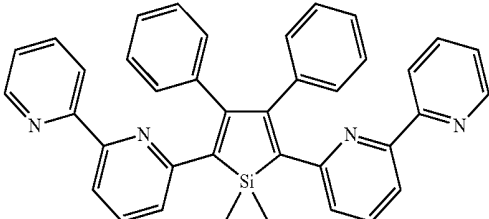
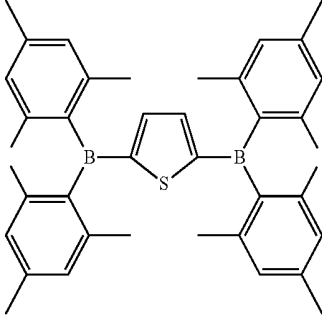
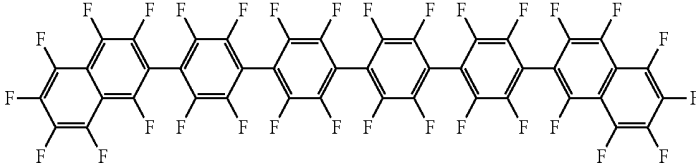
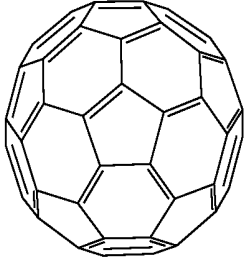
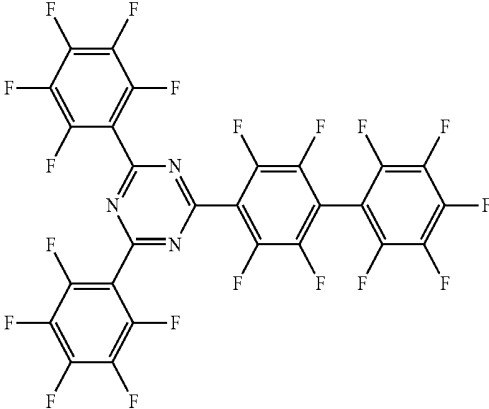
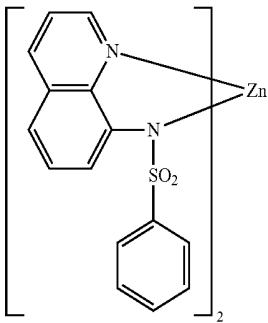
shown in table 1. Geometry optimization calculations were performed within the Gaussian 09 software package using the B3LYP hybrid functional and CEP-31g effective core potential basis set.

TABLE 1

Calculation results of compound 1 and comparative compounds					
Compound number	Structure	HOMO (eV)	LUMO (eV)	S <sub>1</sub> (nm)	T <sub>1</sub> (nm)
Compound 1		-5.05	-1.55	413	473
Compound A		-5.06	-0.48	342	387
Compound B		-5.26	-1.56	412	479

TABLE 1-continued

Calculation results of compound 1 and comparative compounds					
Compound number	Structure	HOMO (eV)	LUMO (eV)	S <sub>1</sub> (nm)	T <sub>1</sub> (nm)
Compound C		-5.15	-1.77	435	488

Table 1 summarizes the HOMO, LUMO energy levels, singlet energy (S<sub>1</sub>), and triplet energy (T<sub>1</sub>) of Compounds 1, A, B, and C. The T<sub>1</sub> of Compound 1 is 473 nm, which is very close to that of Compound B (479 nm). From the molecular orbital diagrams for the LUMO (right) and HOMO (left) of Compound 1 shown in FIG. 4, it is evident that the HOMO is mainly on iridium metal and bottom phenyl ring, while the LUMO is mainly on the pyridine coordinated to platinum with some contributions from phenyl and imidazole ring. This HOMO-LUMO distribution should improve the stability of the complex without affecting the emitting color. Compound C has the iridium moiety and platinum moiety connected directly by a single bond. The calculated T<sub>1</sub> is 15

nm red shifted compared to Compound 1. Therefore, Compound C would not be a suitable blue light emitting material.

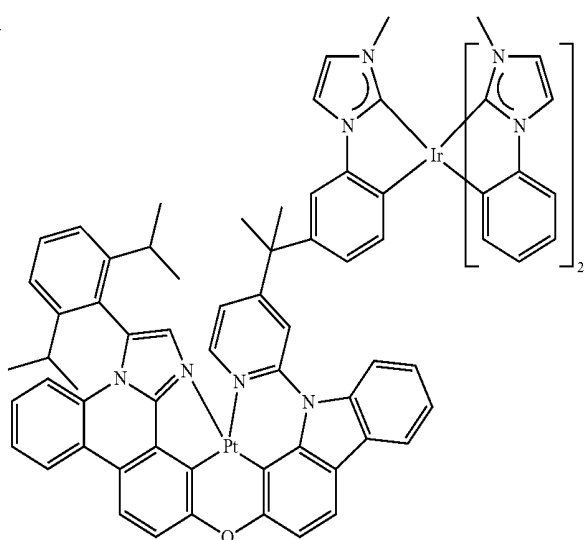
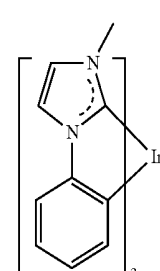
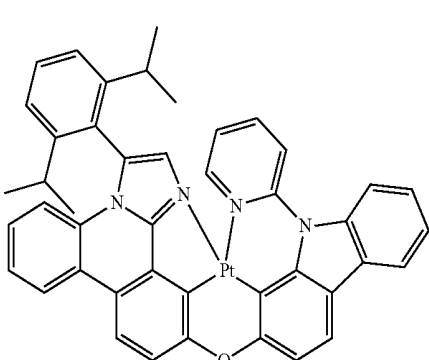
#### General Method of Making Ir/Pt Complexes

The inventive Ir/Pt complexes may be prepared by processes known to those skilled in the art. Suitable processes are mentioned, for example, in WO2012170463 and US20120223634 and the literatures cited therein. The inventive complexes can be purified by processes known to those skilled in the art. Typically, the workup and purification are affected by extraction, column chromatography, recrystallization, and/or sublimation by processes known to those skilled in the art. A schematic process that could be used for preparing compound 5 is detailed below:

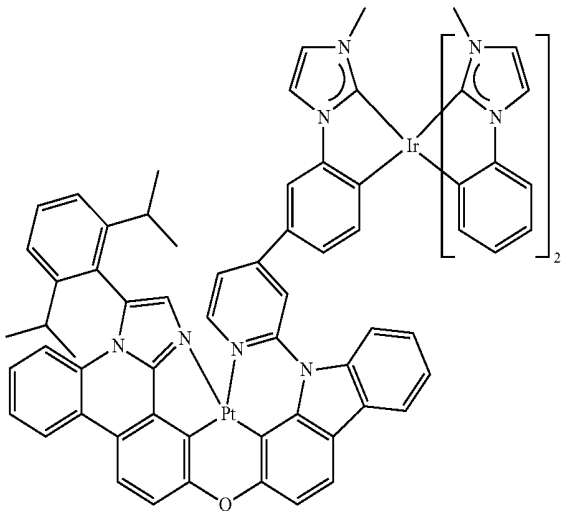
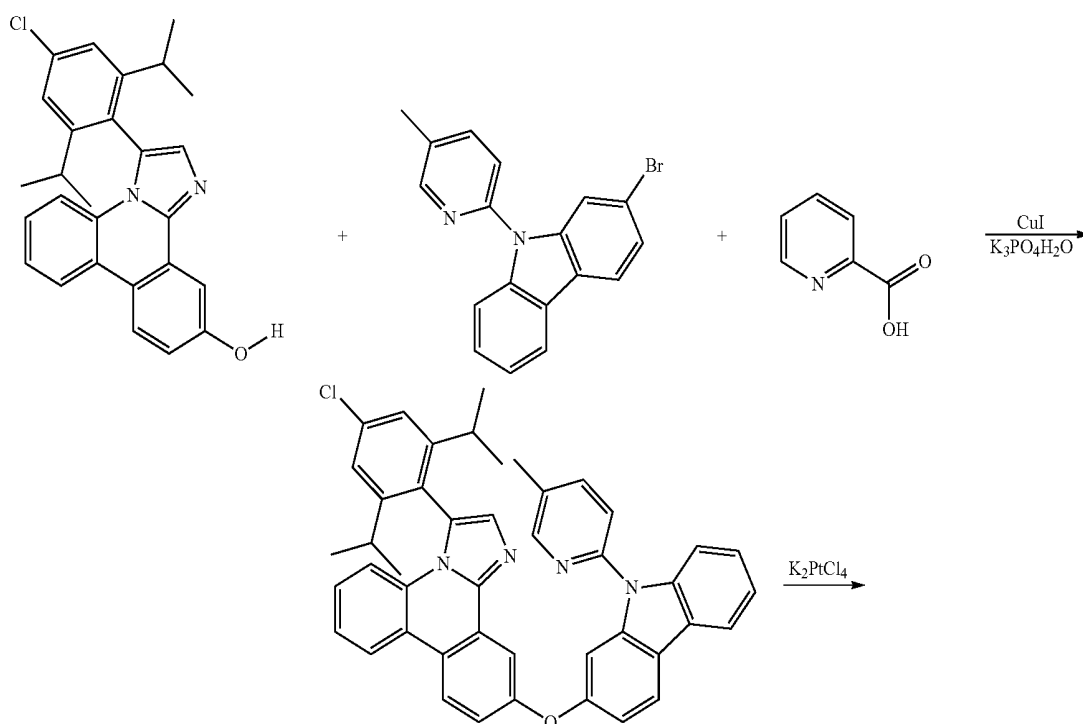

129

130

-continued

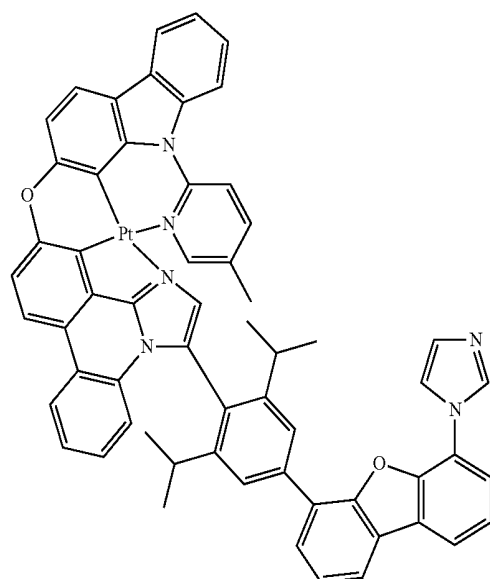
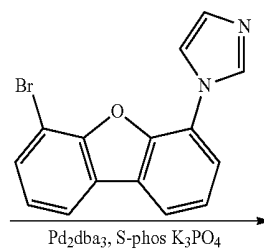
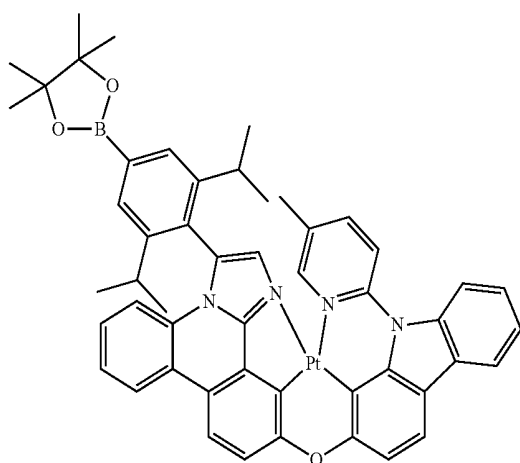
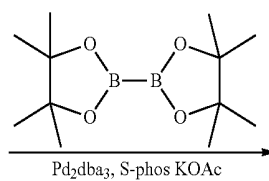
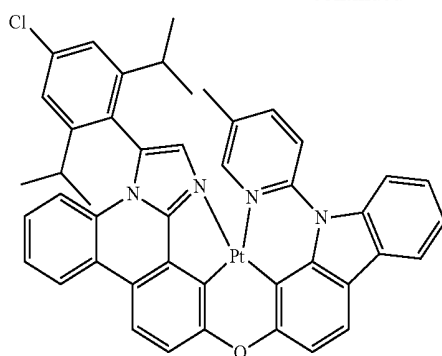
CH<sub>3</sub>I/DMF

131

132

-continued

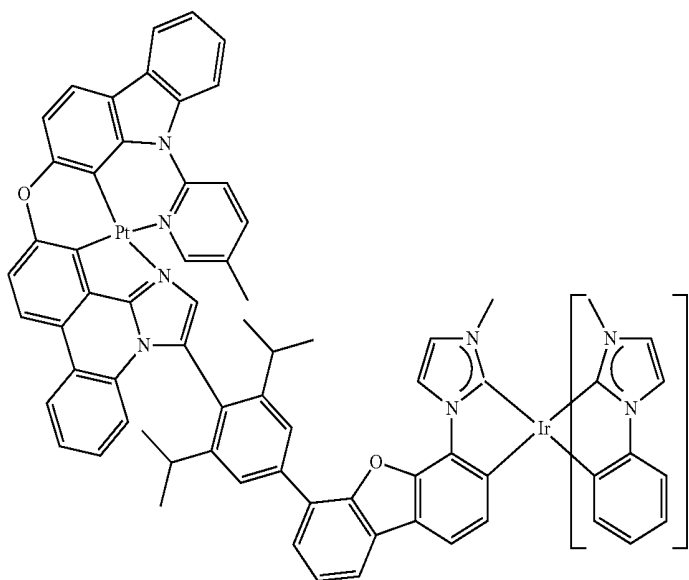
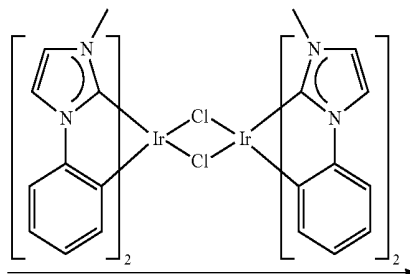
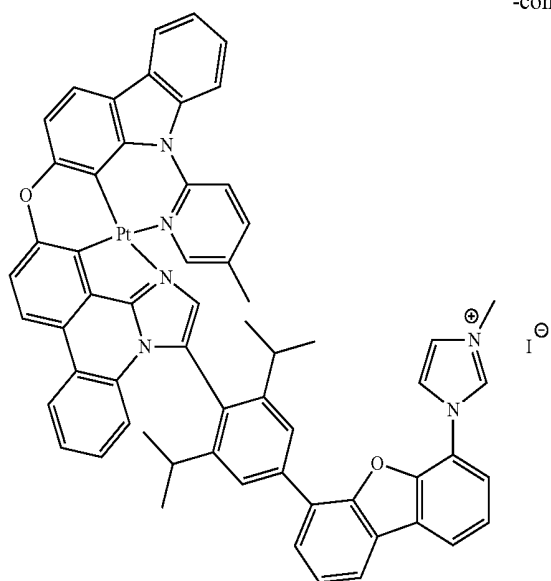

Compound 5

It is understood that the various embodiments described herein are by way of example only, and are not intended to limit the scope of the invention. For example, many of the materials and structures described herein may be substituted with other materials and structures without deviating from the spirit of the invention. The present invention as claimed may therefore include variations from the particular examples and preferred embodiments described herein, as will be apparent to one of skill in the art. It is understood that various theories as to why the invention works are not intended to be limiting.

We claim:

1. A compound comprising the formula

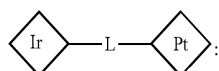

wherein



represents an Ir moiety;  
wherein



represents a Pt moiety;

wherein L represents an organic moiety;  
wherein the formula comprises a first Ir moiety that is an Ir(III) six-coordinated structure;

133

wherein the formula comprises a first Pt moiety that is a Pt(II) four-coordinated structure; and wherein the first Pt moiety comprises a Pt tetradentate structure.

2. The compound of claim 1, wherein the first Ir moiety comprises an Ir tris-bidentate structure.

3. The compound of claim 1, wherein the organic moiety comprises a chemical group selected from the group consisting of alkyl, cycloalkyl, heteroalkyl, arylalkyl, alkoxy, aryloxy, amino, silyl, alkenyl, cycloalkenyl, heteroalkenyl, alkynyl, aryl, heteroaryl, and combinations thereof.

4. The compound of claim 3, wherein the organic moiety comprises a chemical group selected from the group consisting of alkyl, cycloalkyl, amino, silyl, aryl, heteroaryl and combinations thereof.

5. The compound of claim 3, wherein the organic moiety comprises a chemical group selected from the group consisting of methyl, ethyl, propyl, 1-methylethyl, butyl, 1-methylpropyl, 2-methylpropyl, pentyl, 1-methylbutyl, 2-methylbutyl, 3-methylbutyl, 1,1-dimethylpropyl, 1,2-dimethylpropyl, 2,2-dimethylpropyl, cyclopentyl, cyclohexyl, phenyl, biphenyl, triphenylene, terphenyl, tetraphenyl, pentaphenyl, pyridine, phenyl pyridine, pyridyl phenyl, fluorene, carbazole, dibenzothiophene, dibenzofuran, dibenzoselenophene, azacarbazole, aza-dibenzothiophene, aza-dibenzofuran, aza-dibenzoselenophene, partially or fully deuterated variants thereof, and combinations thereof.

6. The compound of claim 1, wherein the compound further comprises a second Ir moiety.

7. The compound of claim 1, wherein the compound further comprises a second Pt moiety.

8. The compound of claim 1, wherein the compound has an emissive spectrum having a peak wavelength of about 400 nm to about 480 nm.

9. The compound of claim 1, wherein the compound emits yellow to orange light with a full width at half maximum between about 70 nm to about 110 nm when the light has a peak wavelength between about 530 nm to about 580 nm.

10. The compound of claim 1, wherein the total number of metal atoms is 2 to 7.

11. The compound of claim 1, wherein the compound is neutral.

12. The compound of claim 1, wherein the first Ir moiety comprises an Ir six-coordinated structure having at least one ligand or part of the ligand if the ligand is more than bidentate selected from the group consisting of:

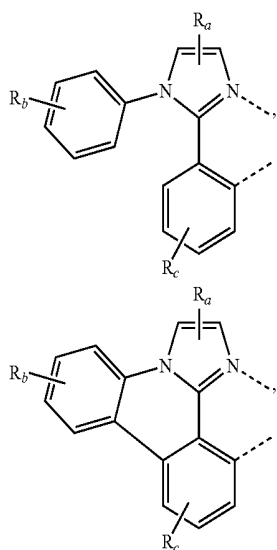

134

-continued

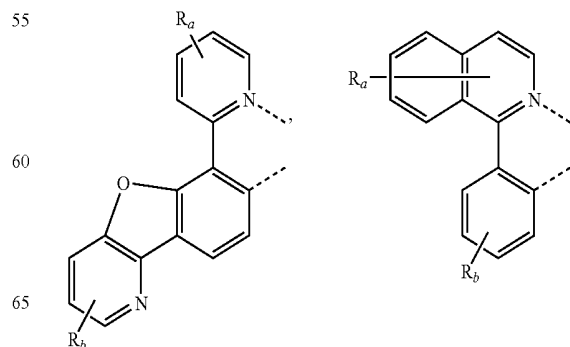
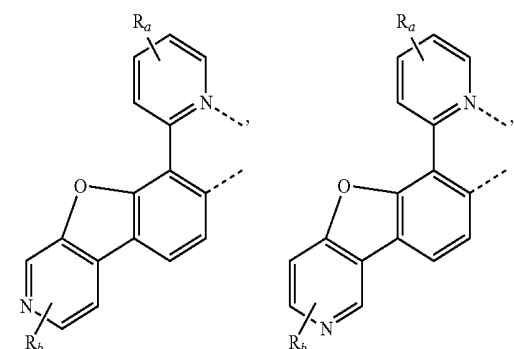
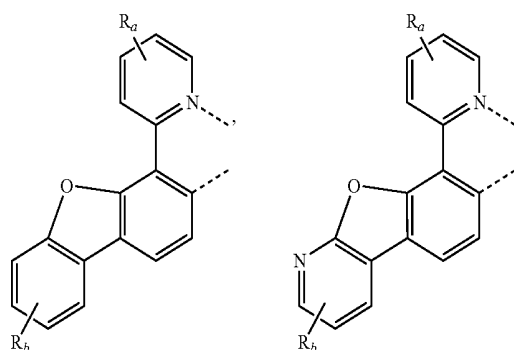
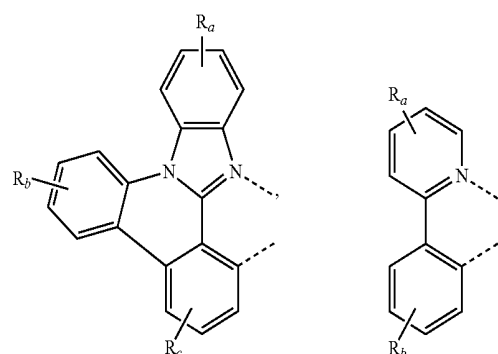
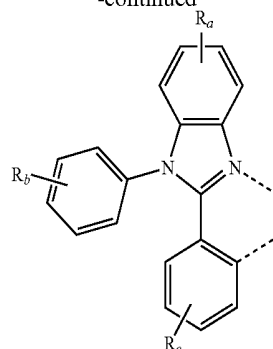

135

-continued

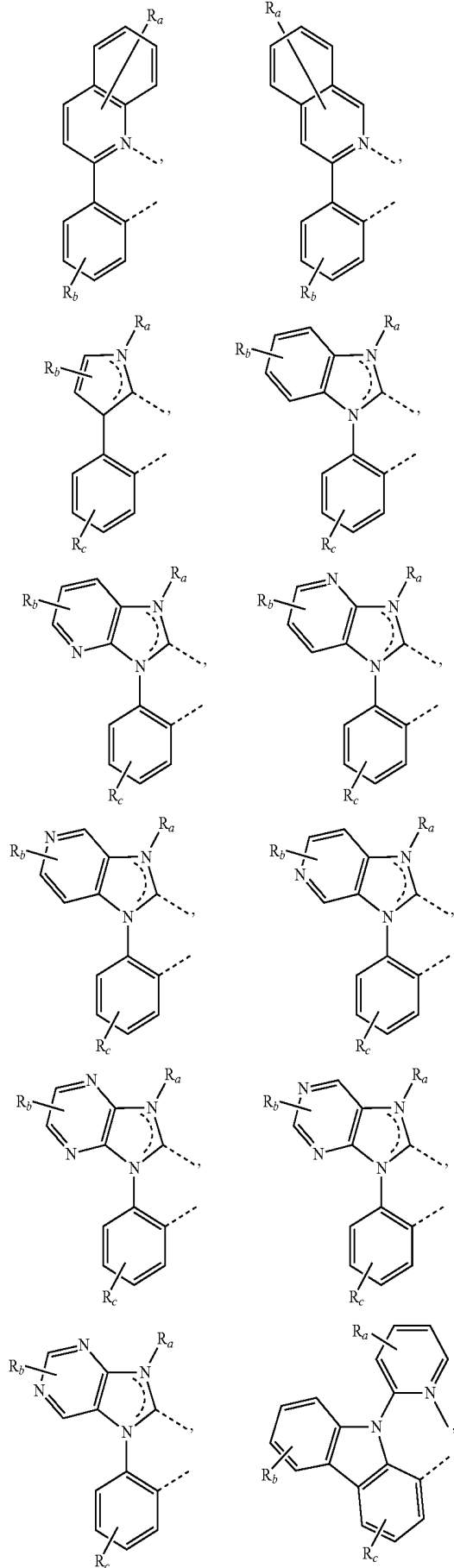

136

-continued

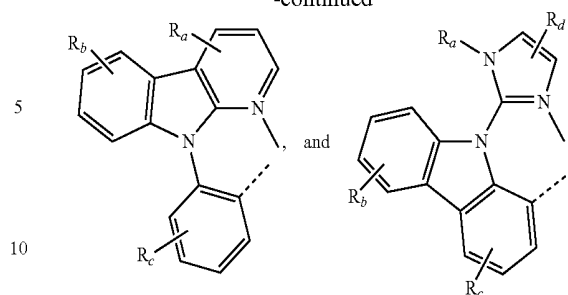

wherein  $R_a$ ,  $R_b$ ,  $R_c$ , and  $R_d$  may represent mono, di, tri, or tetra substitution, or no substitution;

wherein  $R_a$ ,  $R_b$ ,  $R_c$ , and  $R_d$  are independently selected from the group consisting of hydrogen, deuterium, halide, alkyl, cycloalkyl, heteroalkyl, arylalkyl, alkoxy, aryloxy, amino, silyl, alkenyl, cycloalkenyl, heteroalkenyl, alkynyl, aryl, heteroaryl, acyl, carbonyl, carboxylic acids, ester, nitrile, isonitrile, sulfanyl, sulfinyl, sulfonyl, phosphino, and combinations thereof; and wherein two adjacent substituents of  $R_a$ ,  $R_b$ ,  $R_c$ , and  $R_d$  are optionally joined to form a fused ring or form a multidentate ligand.

13. The compound of claim 12, wherein the first Ir moiety comprises an Ir six-coordinated structure having at least one ligand or part of the ligand if the ligand is more than bidentate selected from the group consisting of:

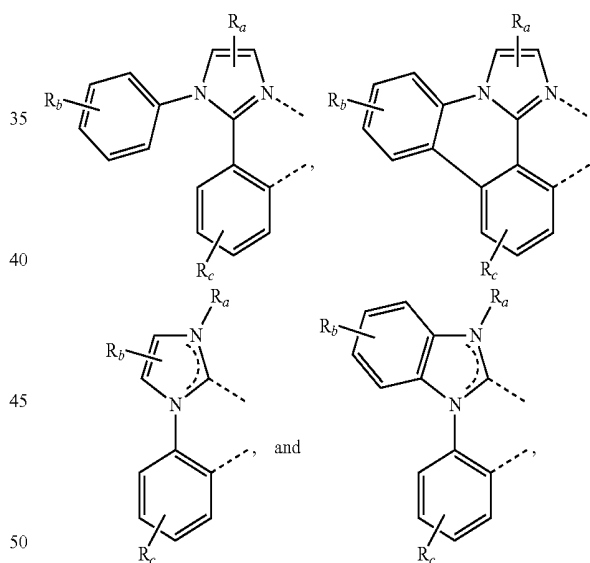

wherein  $R_a$ ,  $R_b$  and  $R_c$  may represent mono, di, tri, or tetra substitution, or no substitution;

wherein  $R_a$ ,  $R_b$  and  $R_c$  are independently selected from the group consisting of hydrogen, deuterium, halide, alkyl, cycloalkyl, heteroalkyl, arylalkyl, alkoxy, aryloxy, amino, silyl, alkenyl, cycloalkenyl, heteroalkenyl, alkynyl, aryl, heteroaryl, acyl, carbonyl, carboxylic acids, ester, nitrile, isonitrile, sulfanyl, sulfinyl, sulfonyl, phosphino, and combinations thereof; and wherein two adjacent substituents of  $R_a$ ,  $R_b$  and  $R_c$  are optionally joined to form a fused ring or form a multidentate ligand.

14. The compound of claim 1, wherein the first Pt moiety comprises a Pt four-coordinated structure wherein part of the tetradentate ligand is selected from the group consisting of:

137

138

-continued

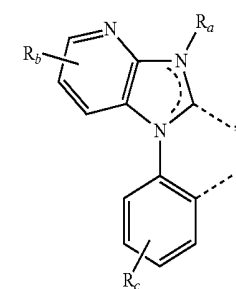
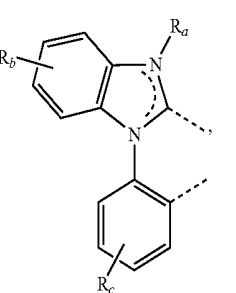
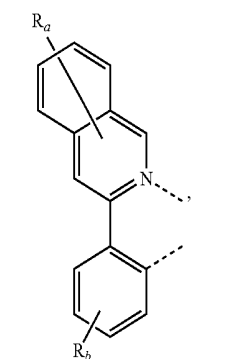
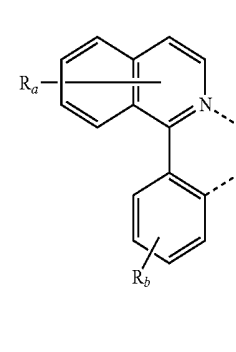
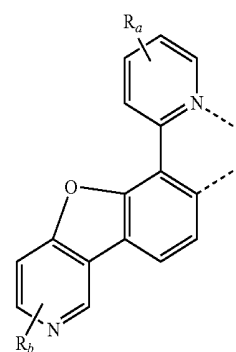
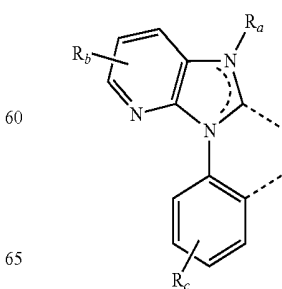
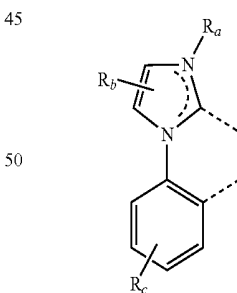
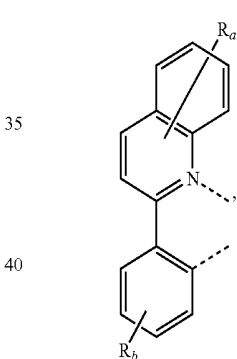
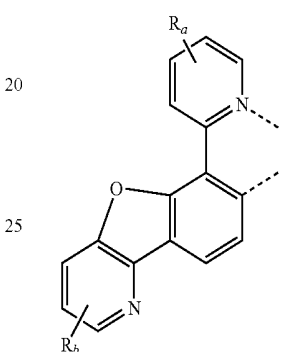
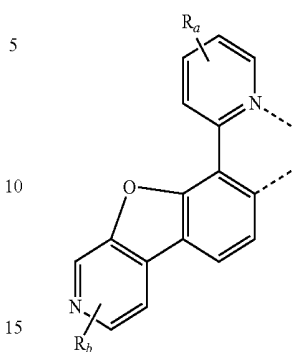
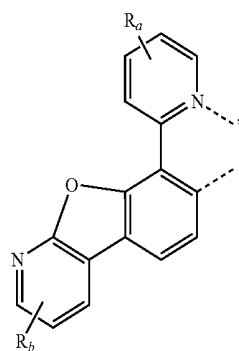
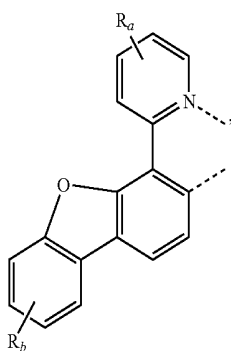
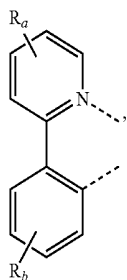
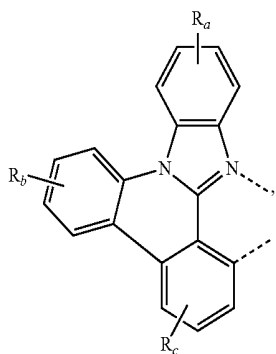
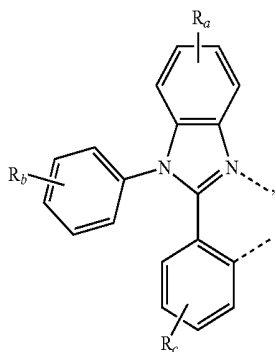
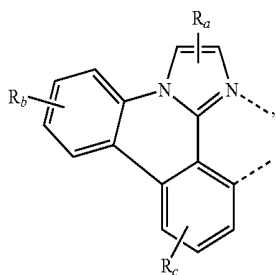
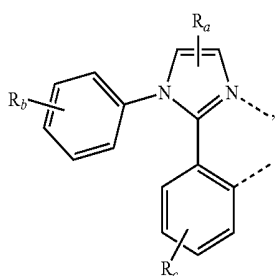

139

-continued

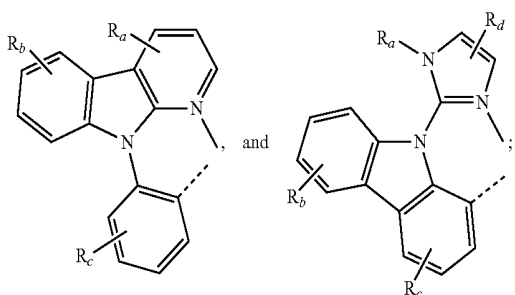
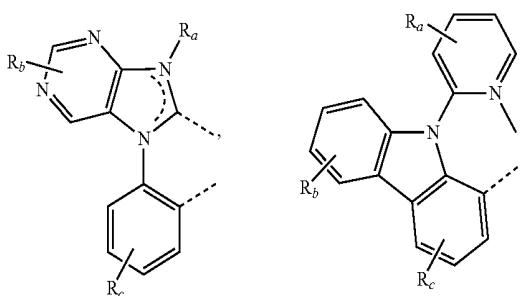
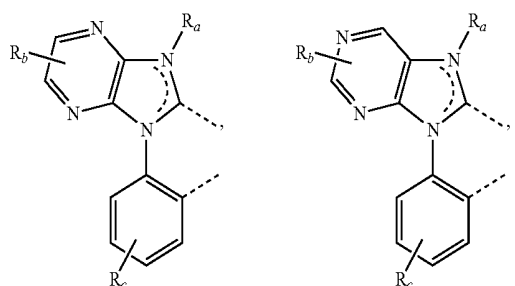
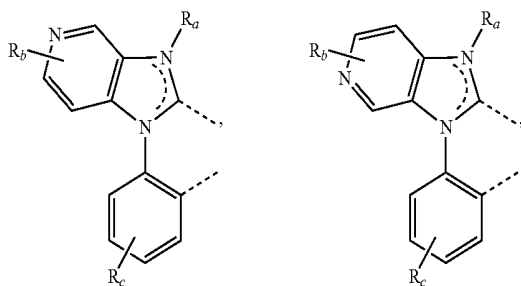

wherein  $R_a$ ,  $R_b$ ,  $R_c$ , and  $R_d$  may represent mono, di, tri, or tetra substitution, or no substitution;

wherein  $R_a$ ,  $R_b$ ,  $R_c$ , and  $R_d$  are independently selected from the group consisting of hydrogen, deuterium, halide, alkyl, cycloalkyl, heteroalkyl, arylalkyl, alkoxy, aryloxy, amino, silyl, alkenyl, cycloalkenyl, heteroalkenyl, alkynyl, aryl, heteroaryl, acyl, carbonyl, carboxylic acids, ester, nitrile, isonitrile, sulfanyl, sulfinyl, sulfonyl, phosphino, and combinations thereof; and wherein two adjacent substituents of  $R_a$ ,  $R_b$ ,  $R_c$ , and  $R_d$  are optionally joined to form a fused ring or form a multidentate ligand.

15. The compound of claim 14, wherein the first Pt moiety comprises a Pt four-coordinated structure, wherein part of the tetradentate ligand is selected from the group consisting of:

140

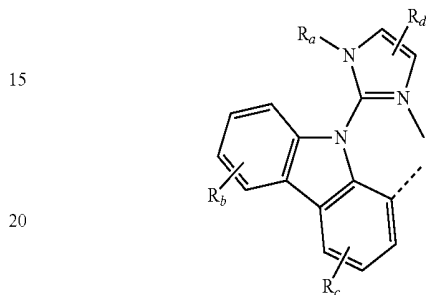
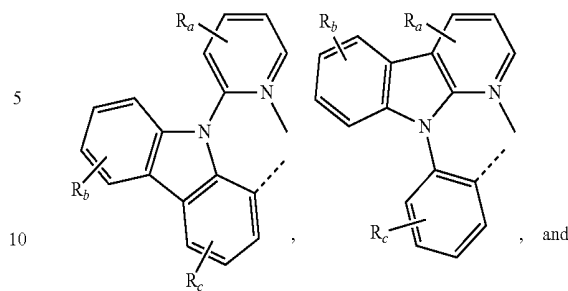

wherein  $R_a$ ,  $R_b$ ,  $R_c$ , and  $R_d$  may represent mono, di, tri, or tetra substitution, or no substitution;

wherein  $R_a$ ,  $R_b$ ,  $R_c$ , and  $R_d$  are independently selected from the group consisting of hydrogen, deuterium, halide, alkyl, cycloalkyl, heteroalkyl, arylalkyl, alkoxy, aryloxy, amino, silyl, alkenyl, cycloalkenyl, heteroalkenyl, alkynyl, aryl, heteroaryl, acyl, carbonyl, carboxylic acids, ester, nitrile, isonitrile, sulfanyl, sulfinyl, sulfonyl, phosphino, and combinations thereof; and wherein two adjacent substituents of  $R_a$ ,  $R_b$ ,  $R_c$ , and  $R_d$  are optionally joined to form a fused ring or form a multidentate ligand.

16. The compound of claim 1, wherein the compound is selected from the group consisting of:

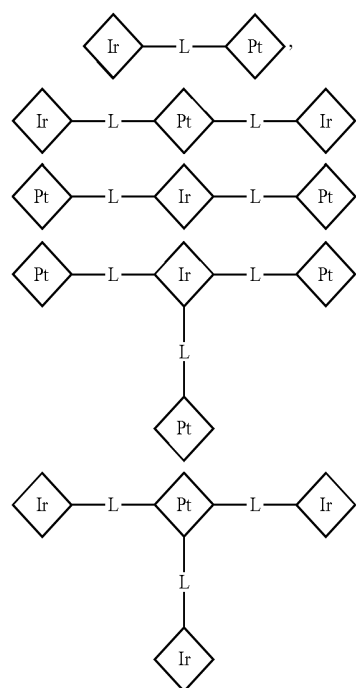

141

-continued

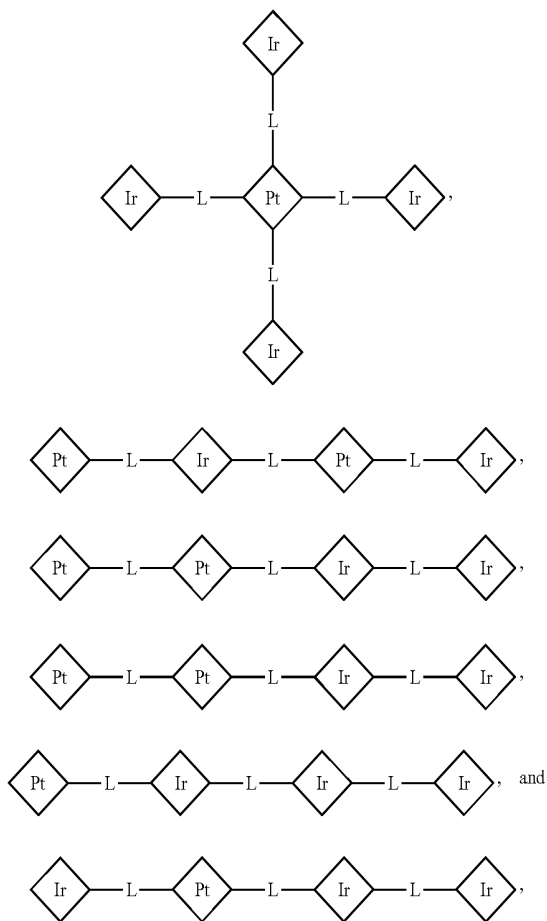

wherein each



represents a Ir moiety;  
wherein each



represents a Pt moiety;  
wherein each L represents an organic moiety; and  
wherein each

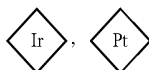

and L can be same or different.

142

17. The compound of claim 1, wherein the first Ir moiety comprises a chemical structure selected from the group consisting of

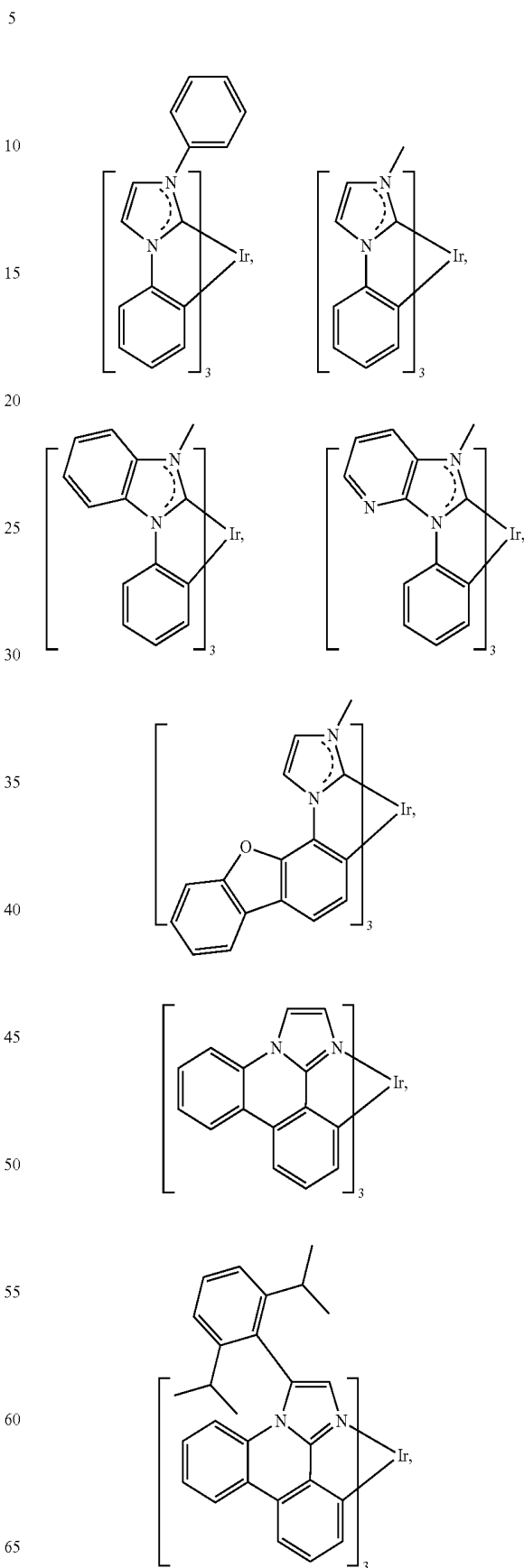

143

-continued

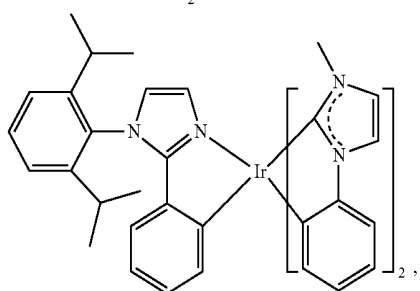
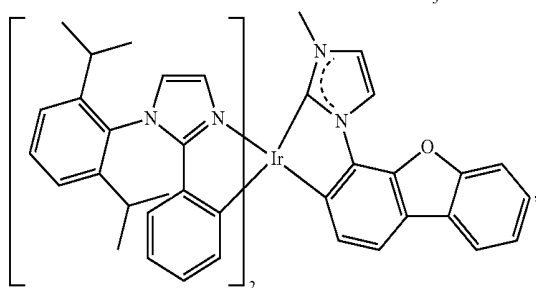
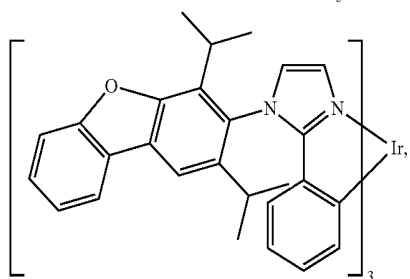
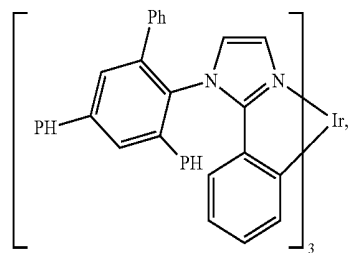
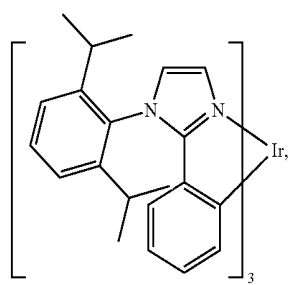
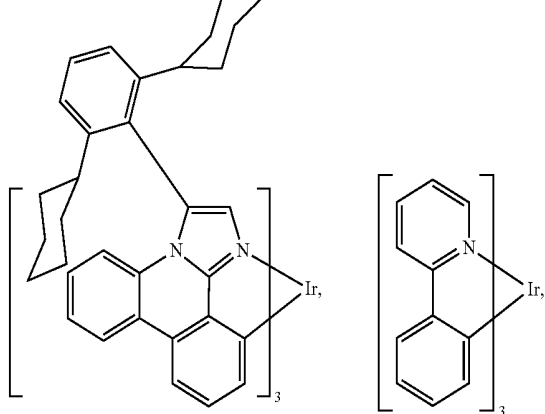

144

-continued

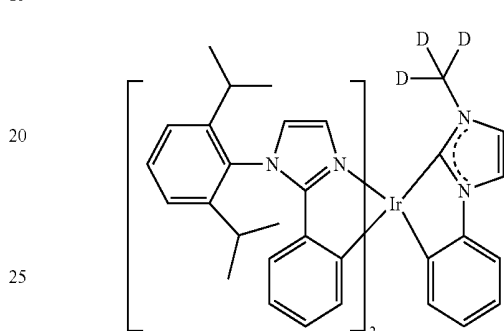
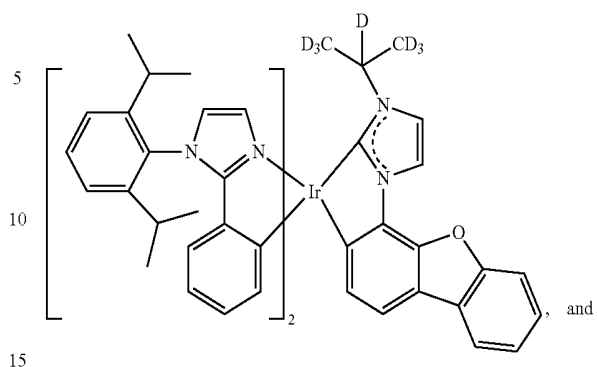

18. The compound of claim 1, wherein the first Pt moiety comprises a chemical structure selected from the group consisting of

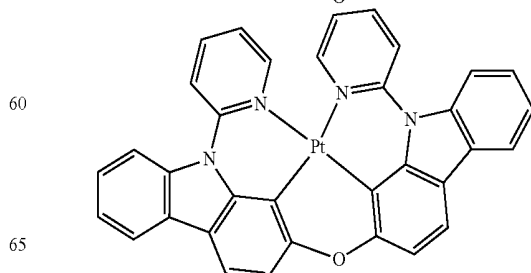
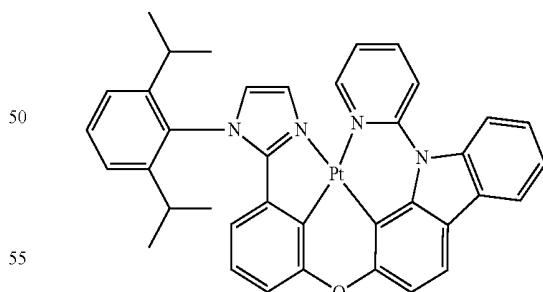
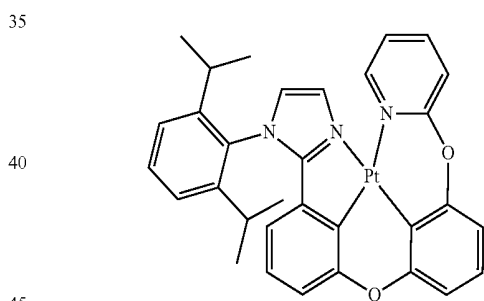

**145**  
-continued

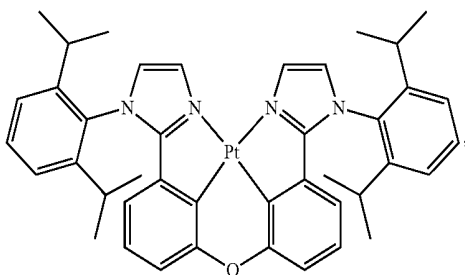
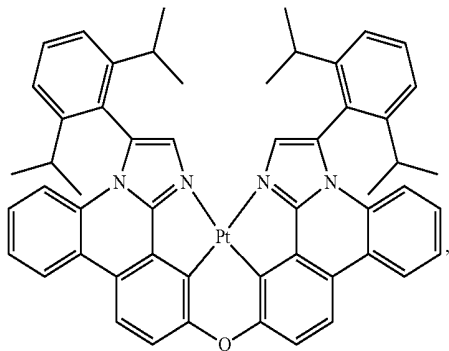
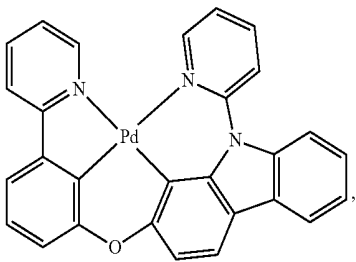
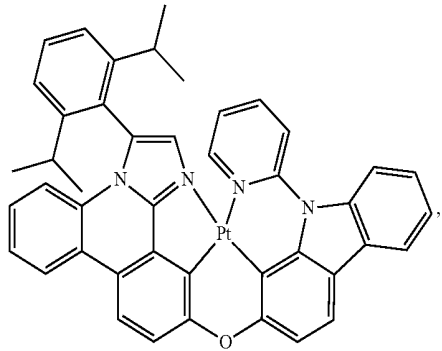

**146**  
-continued

5

10

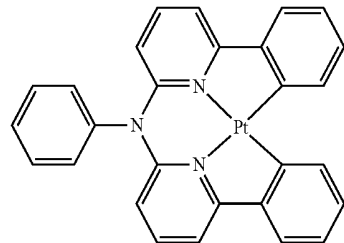

15

20

25

30

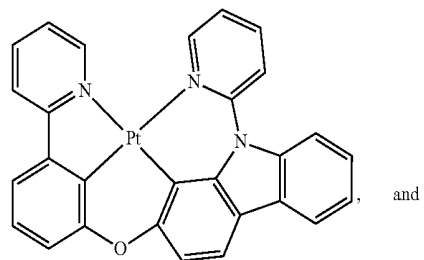

and

35

40

45

50

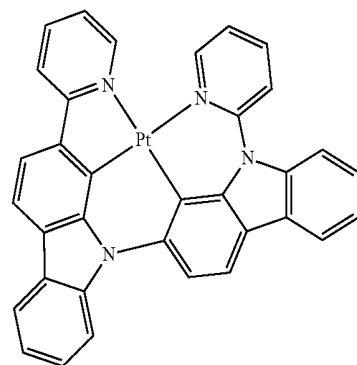

55

60

65

19. The compound of claim 1, wherein the compound is selected from the group consisting of:

147

148

Compound 1

Compound 2

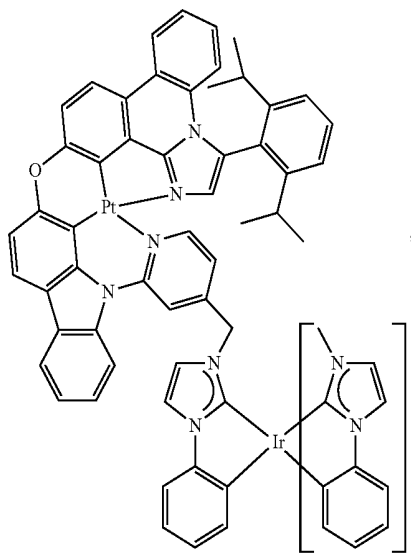
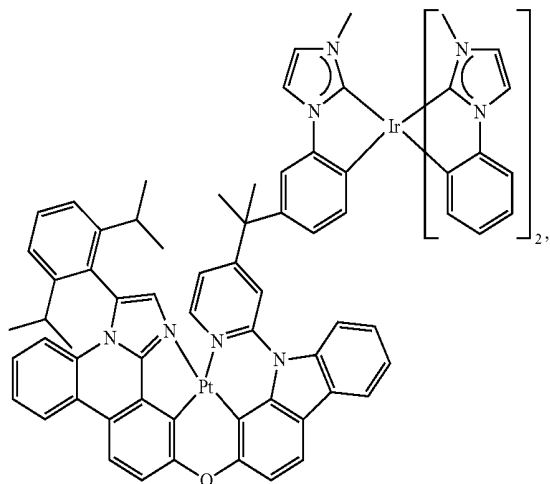

Compound 3

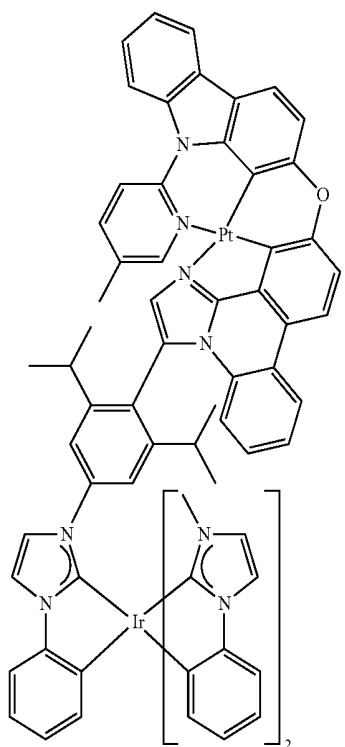

-continued

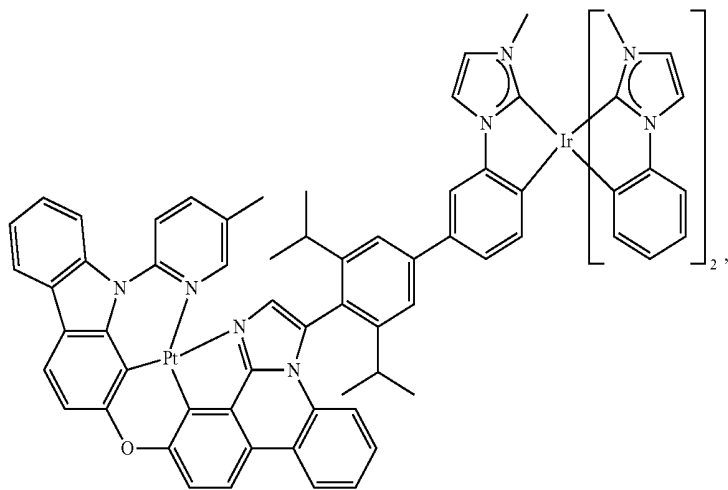

Compound 4

Compound 5

Compound 6

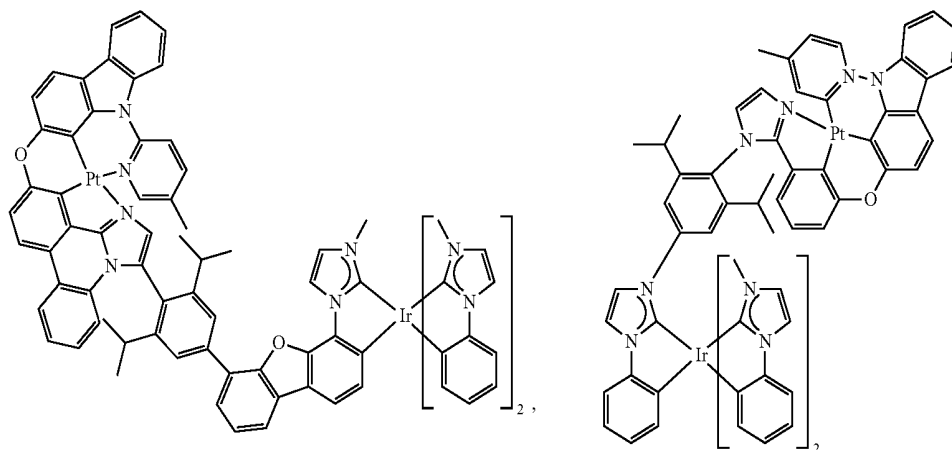

Compound 7

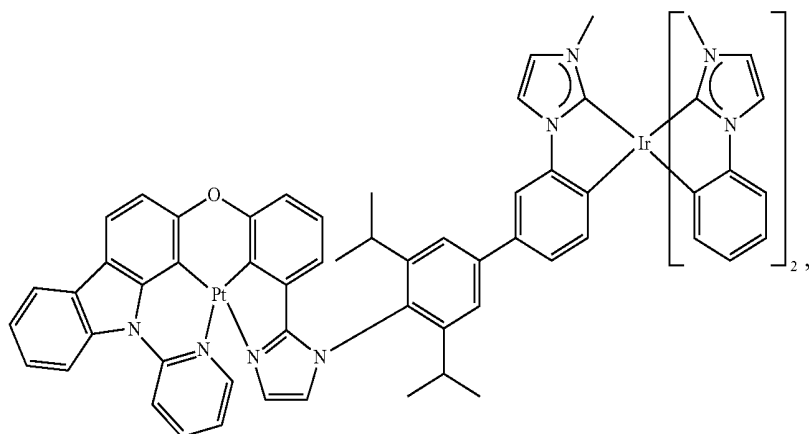

151

152

-continued

Compound 8

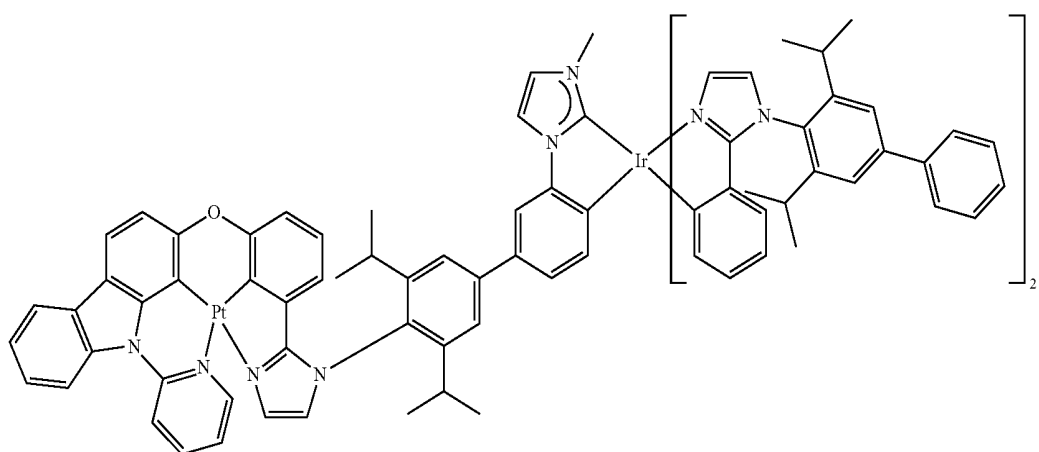
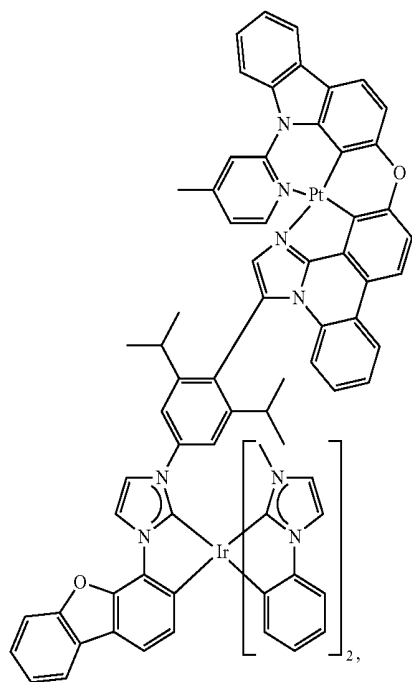

Compound 9

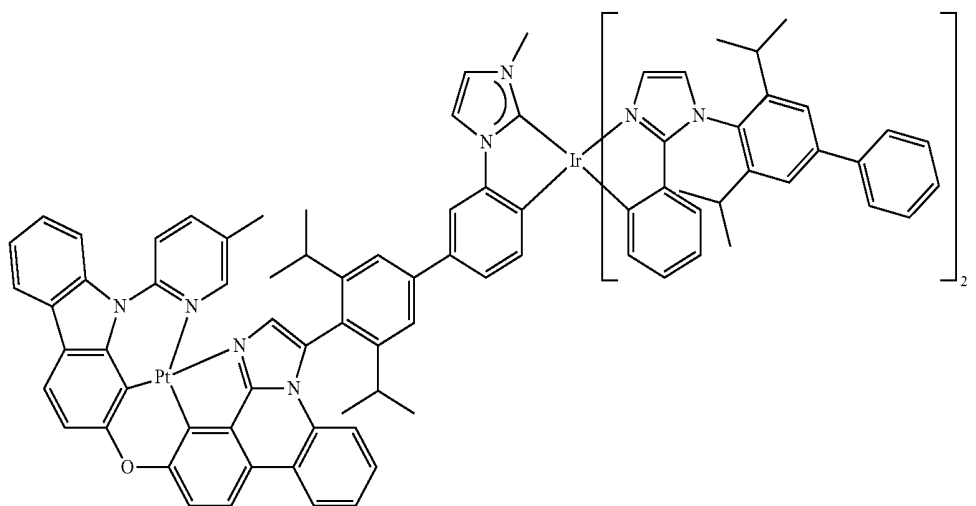

Compound 10

153

154

-continued

Compound 11

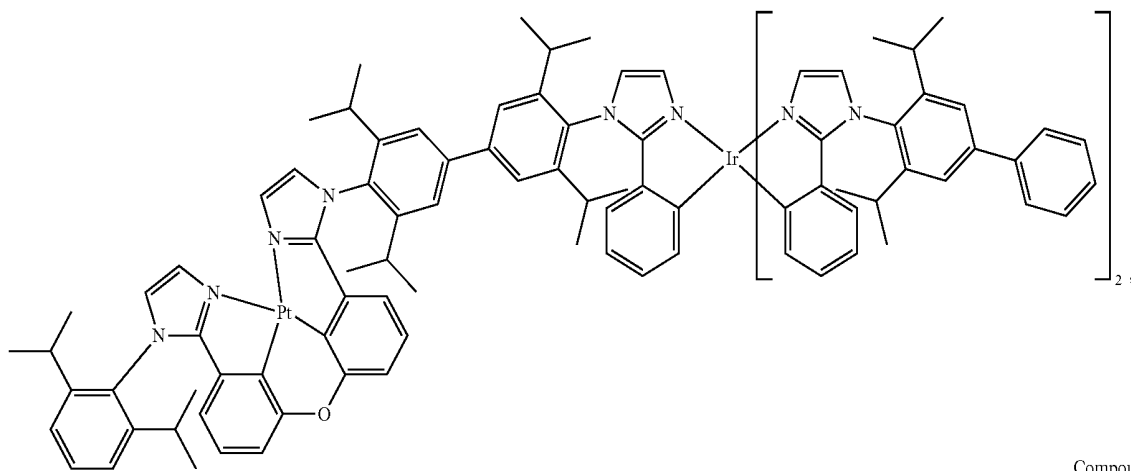

Compound 12

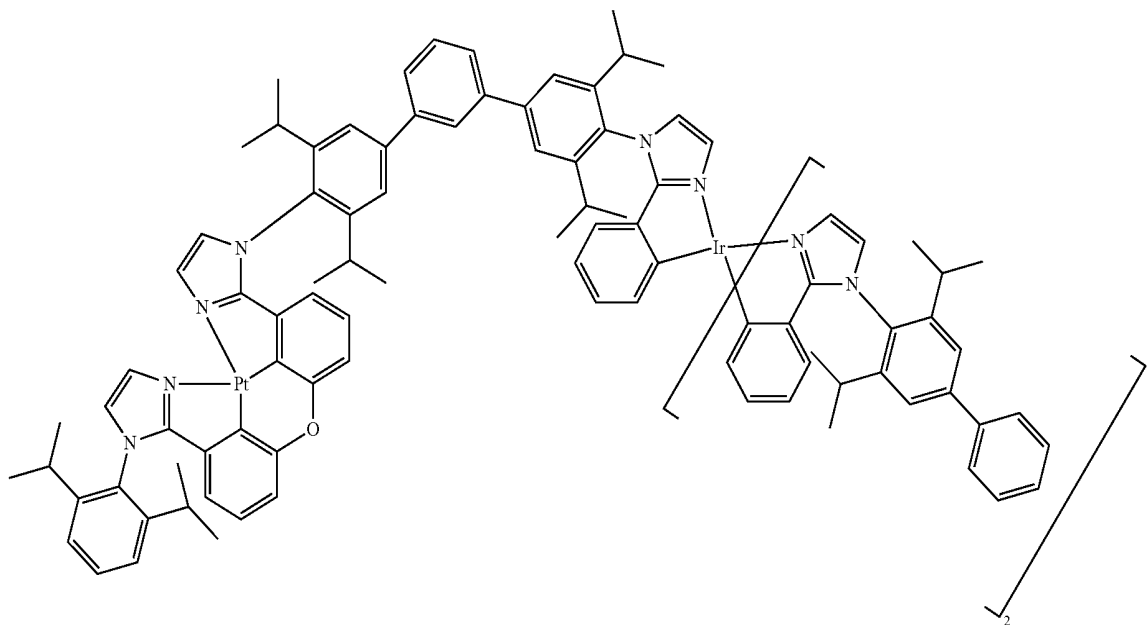

Compound 13

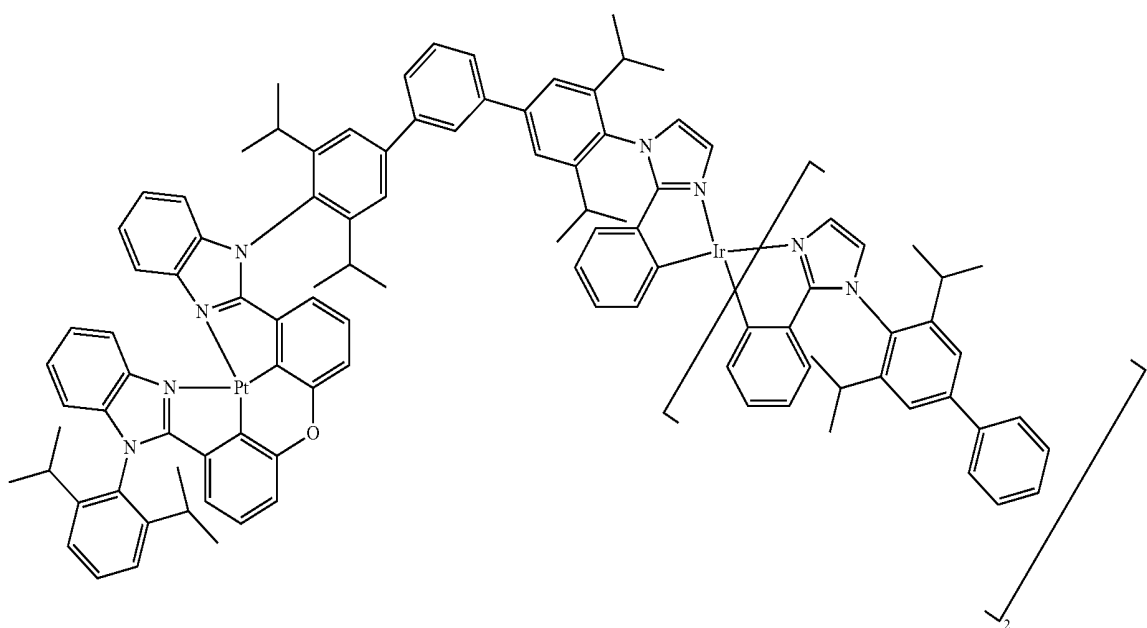

155

156

-continued

Compound 16

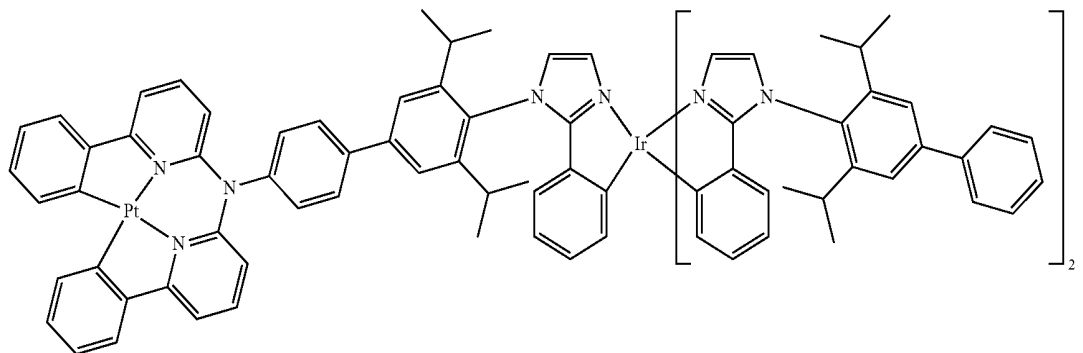

Compound 17

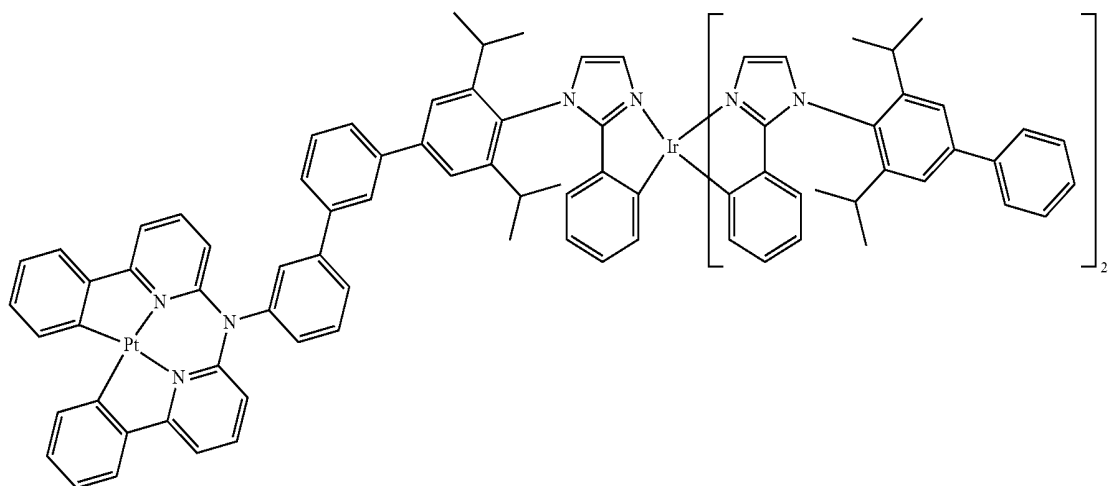

Compound 18

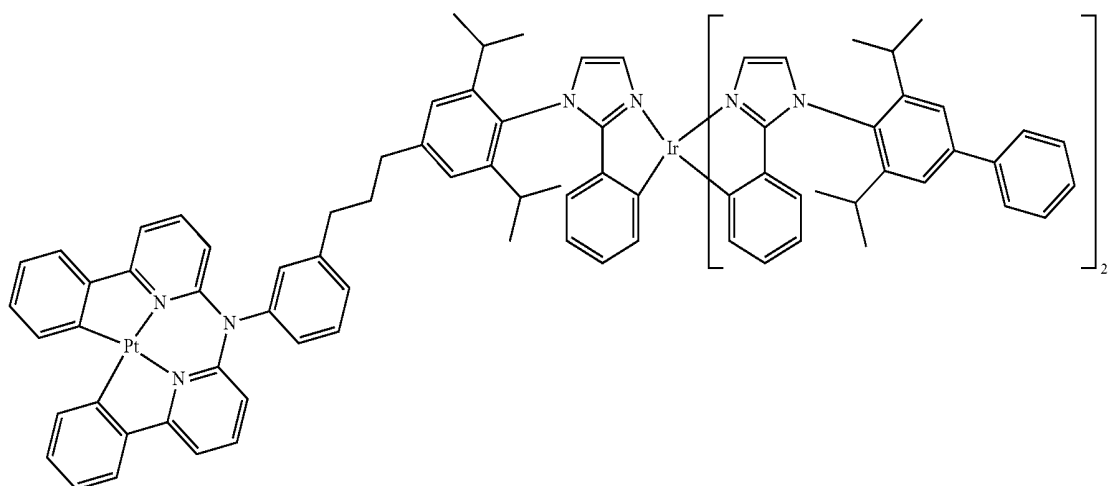

157

158

-continued

Compound 19

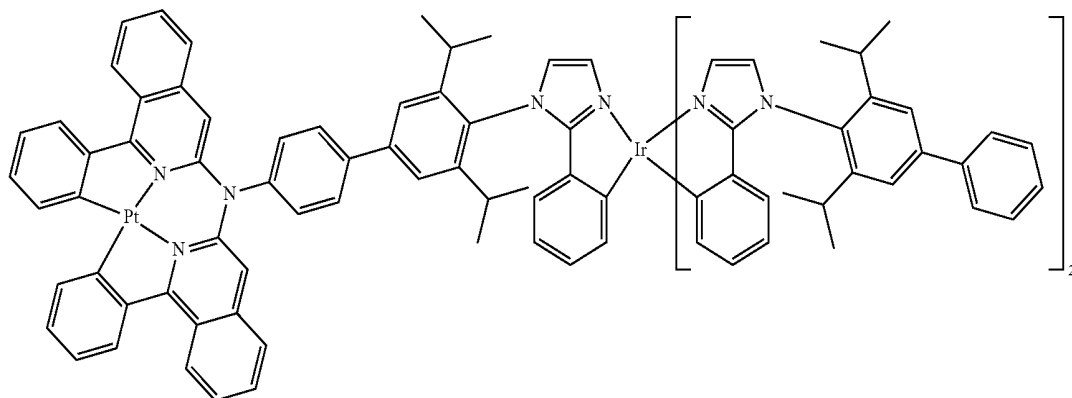

Compound 20

Compound 21

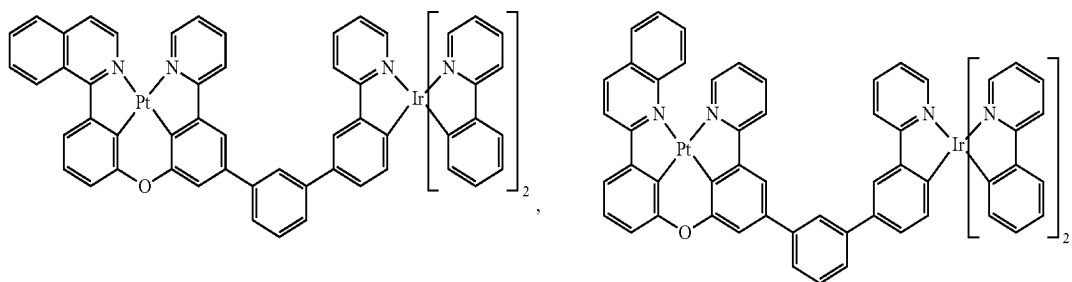

Compound 22

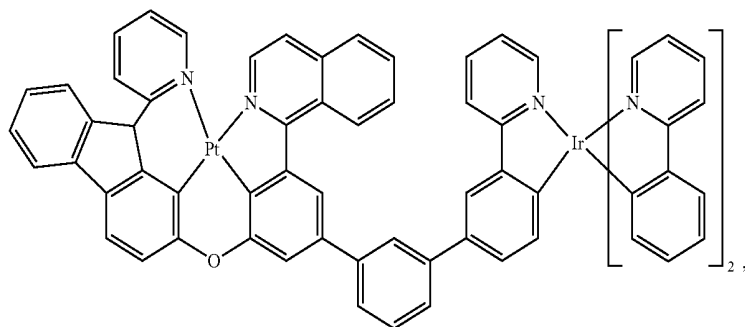

Compound 23

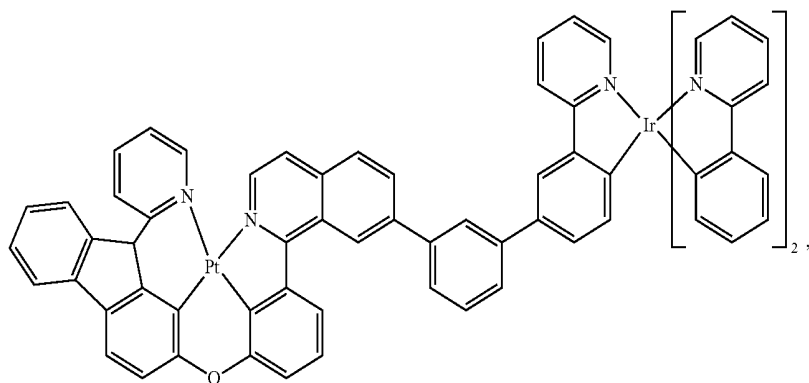

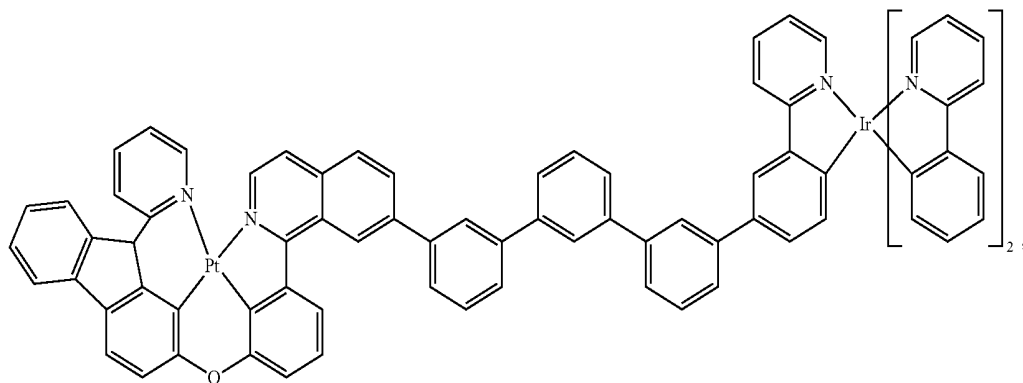

Compound 24

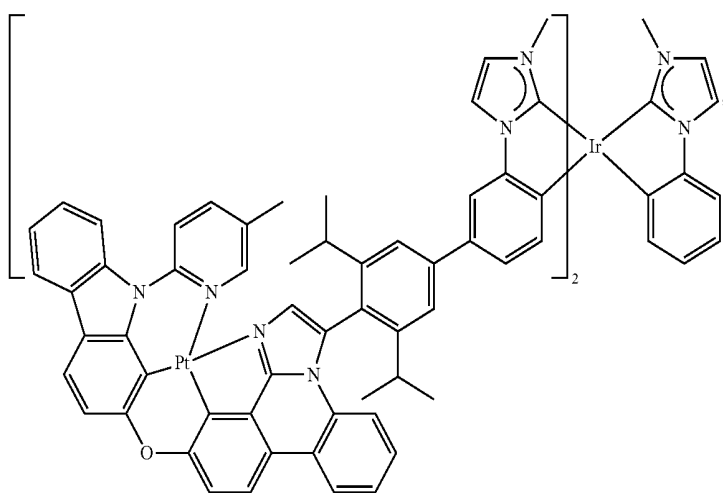

Compound 25

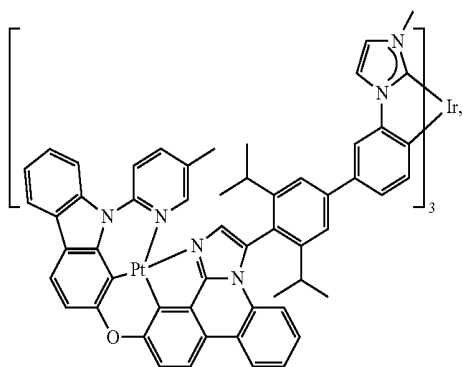

Compound 26

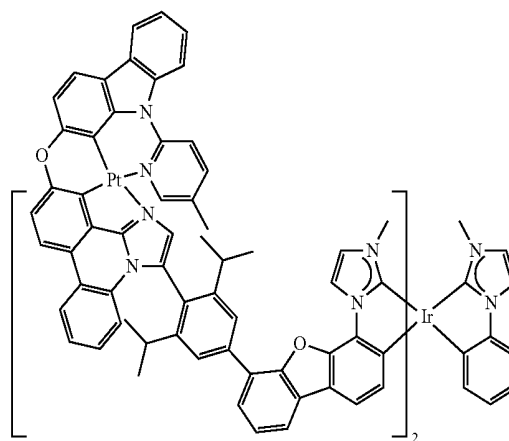

Compound 27

161

162

-continued

Compound 28

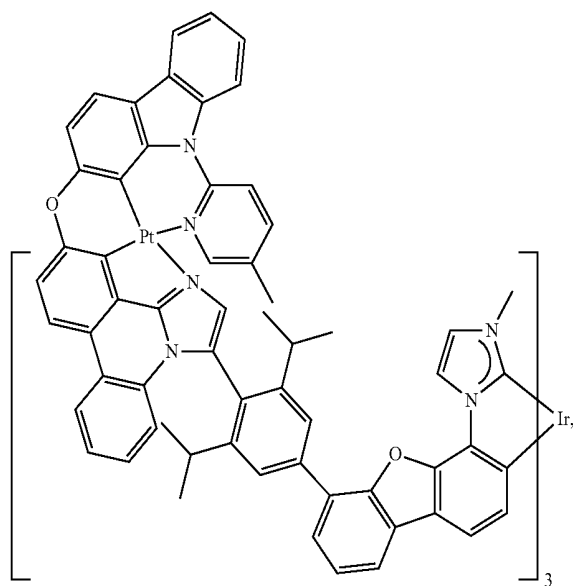

Compound 29

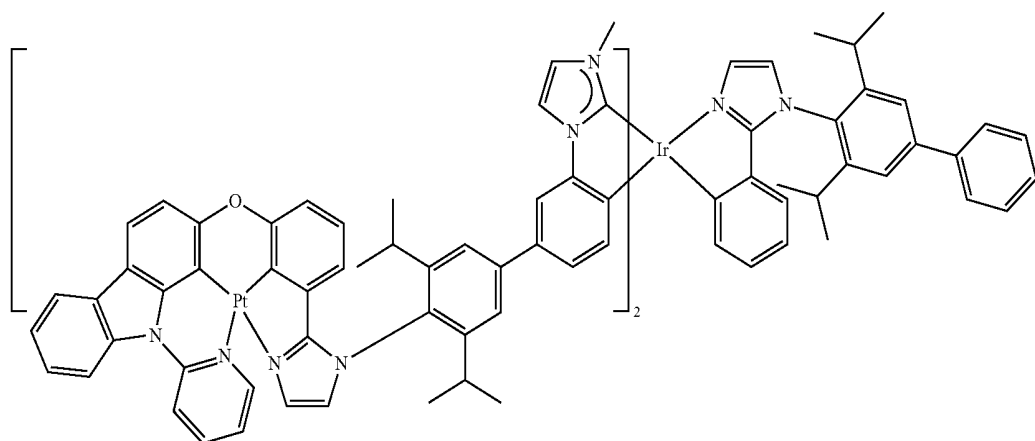

Compound 30

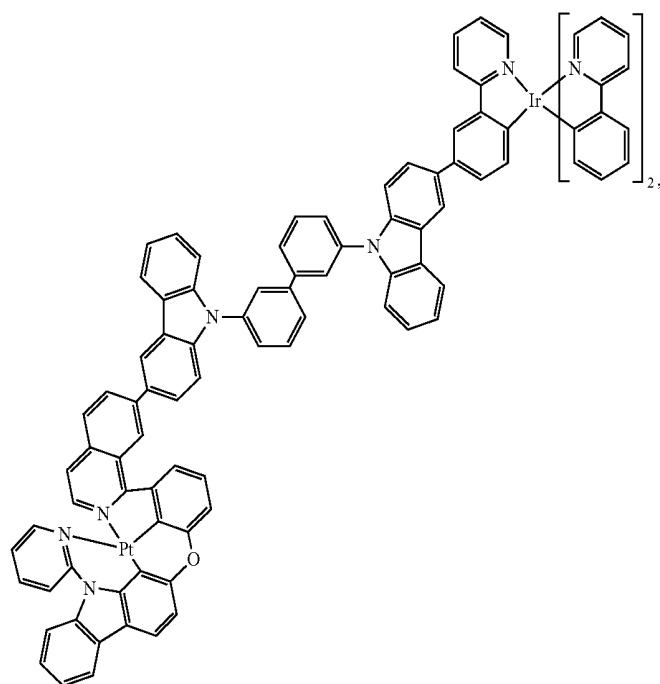

-continued

Compound 31

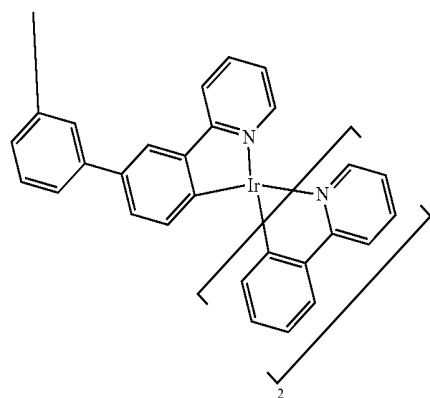
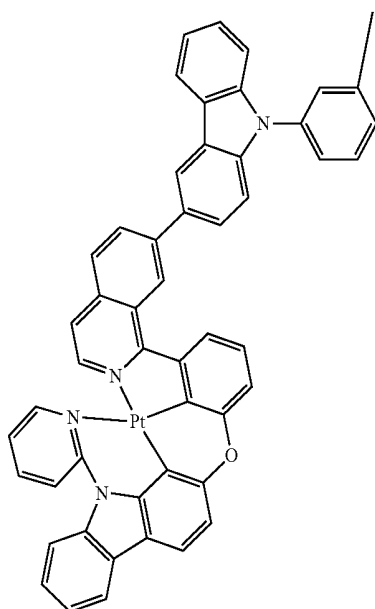
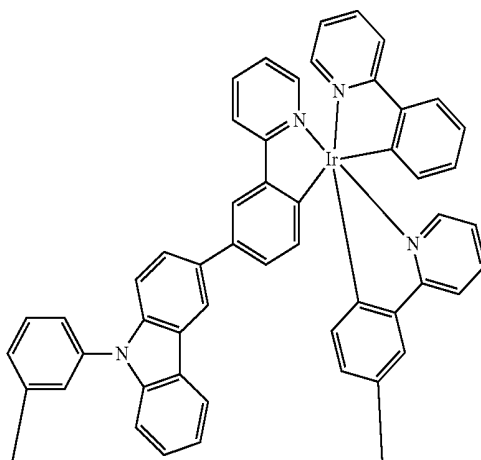

Compound 32

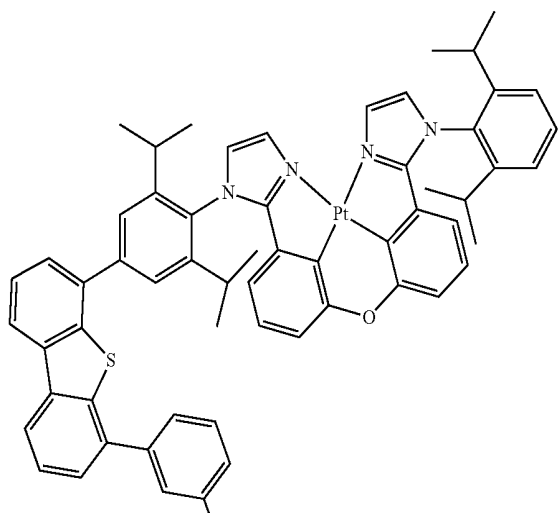

165

166

-continued

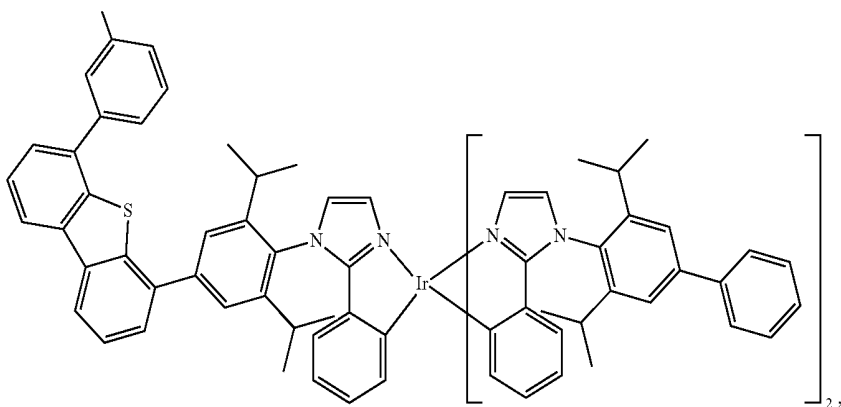

Compound 33

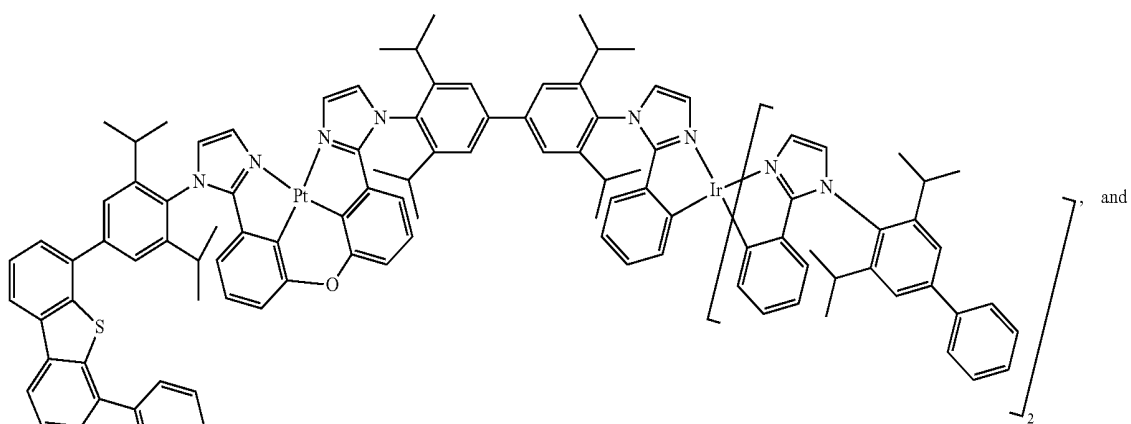

Compound 34

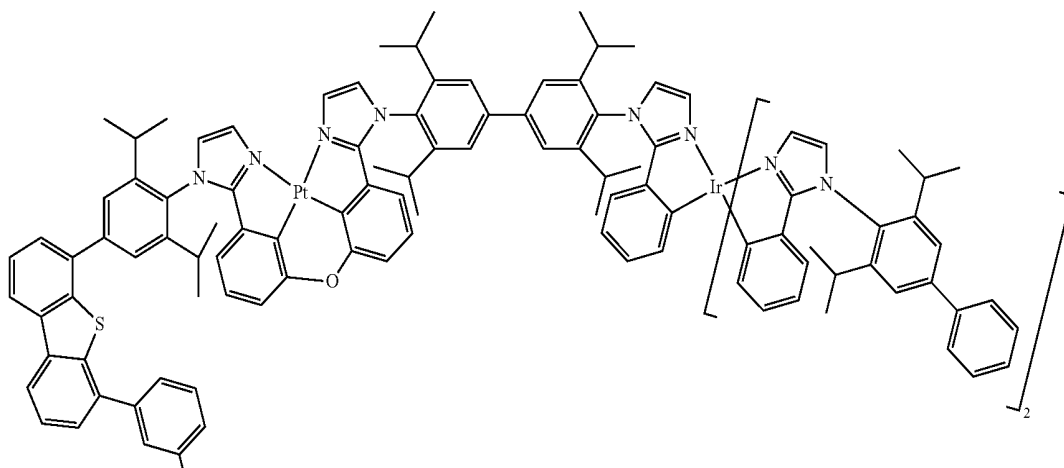
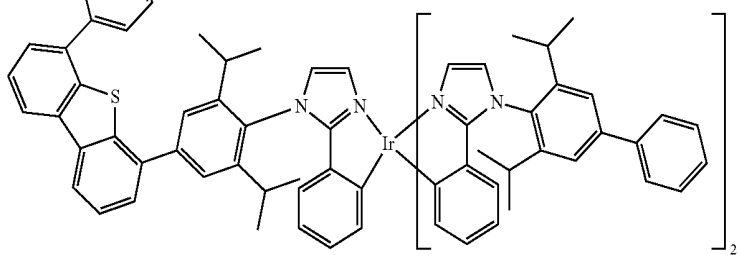

167

168

-continued

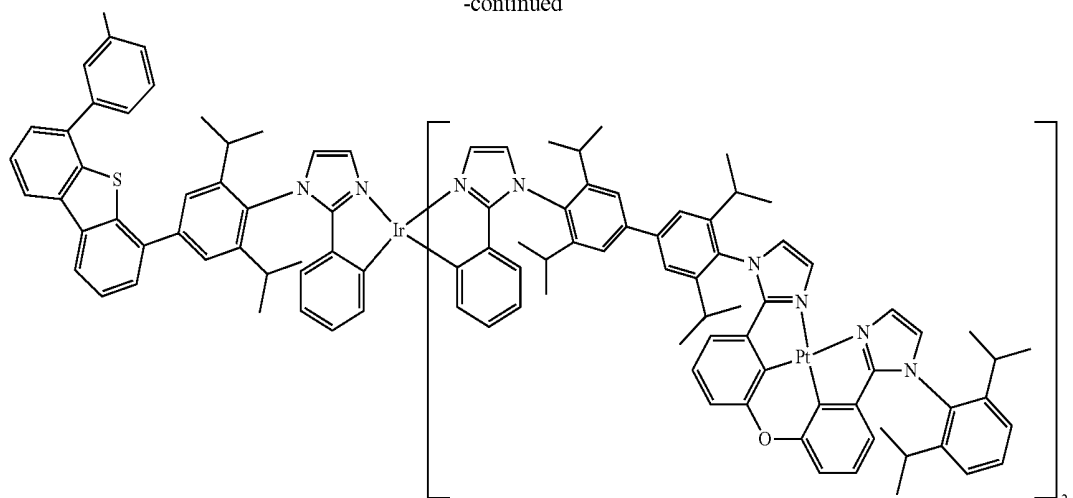

20. A first device comprising a first organic light emitting device, the first organic light emitting device comprising:  
 an anode;  
 a cathode; and  
 an organic layer, disposed between the anode and the cathode, comprising a compound comprising the formula

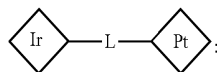

wherein



represents an Ir moiety;  
 wherein



represents a Pt moiety;  
 wherein L represents an organic moiety;  
 wherein the formula comprises a first Ir moiety that is an Ir(III) six-coordinated structure;  
 wherein the formula comprises a first Pt moiety that is a Pt(II) four-coordinated structure; and  
 wherein the first Pt moiety comprises a Pt tetradentate structure.

21. The first device of claim 20, wherein the organic layer is deposited using a solution process.

22. The first device of claim 20, wherein the first device is a consumer product.

23. The first device of claim 20, wherein the first device is an organic light emitting device.

24. The first device of claim 20, wherein the first device comprises a light panel.

25. The first device of claim 20, wherein the organic layer is an emissive layer and the compound is an emissive dopant.

26. The first device of claim 20, wherein the organic layer is an emissive layer and the compound is a non-emissive dopant.

27. The first device of claim 20, wherein the organic layer further comprises a host material.

28. The first device of claim 27, wherein the host material comprises a triphenylene containing benzo-fused thiophene or benzo-fused furan;

wherein any substituent in the host material is an unfused substituent independently selected from the group consisting of  $C_nH_{2n+1}$ ,  $OC_nH_{2n+1}$ ,  $OAr_1$ ,  $N(C_nH_{2n+1})_2$ ,  $N(Ar_1)(Ar_2)$ ,  $CH=CH-C_nH_{2n+1}$ ,  $C\equiv C-C_nH_{2n+1}$ ,  $Ar_1$ ,  $Ar_1-Ar_2$ ,  $C_nH_{2n}-Ar_1$ , or no substitution;

wherein n is from 1 to 10; and  
 wherein  $Ar_1$  and  $Ar_2$  are independently selected from the group consisting of benzene, biphenyl, naphthalene, triphenylene, carbazole, and heteroaromatic analogs thereof.

29. The first device of claim 27, wherein the host material comprises at least one chemical group selected from the group consisting of carbazole, dibenzothiophene, dibenzofuran, dibenzoselenophene, azacarbazole, aza-dibenzothiophene, aza-dibenzofuran, and aza-dibenzoselenophene.

30. The first device of claim 27, wherein the host material is selected from the group consisting of:

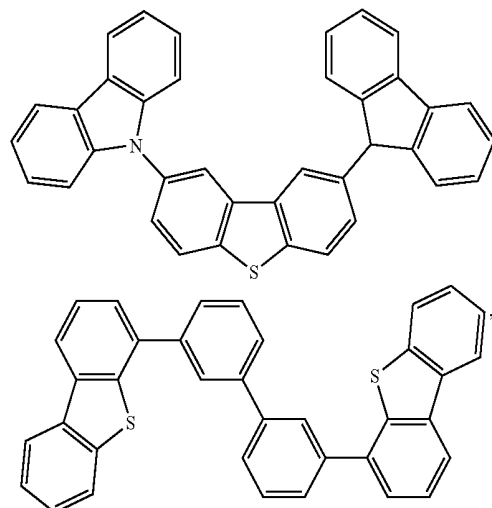

169

-continued

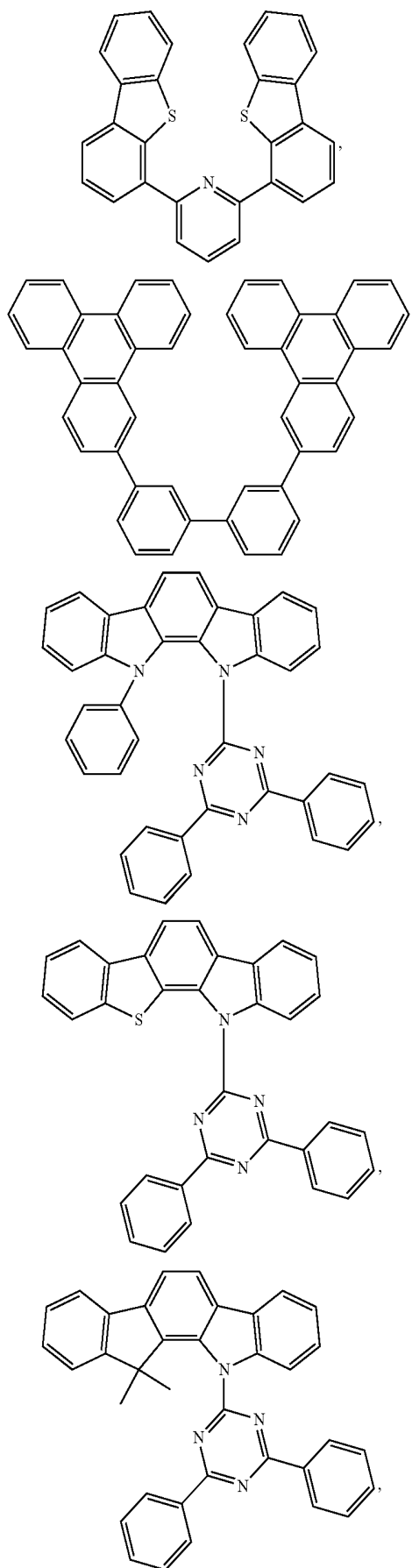

170

-continued

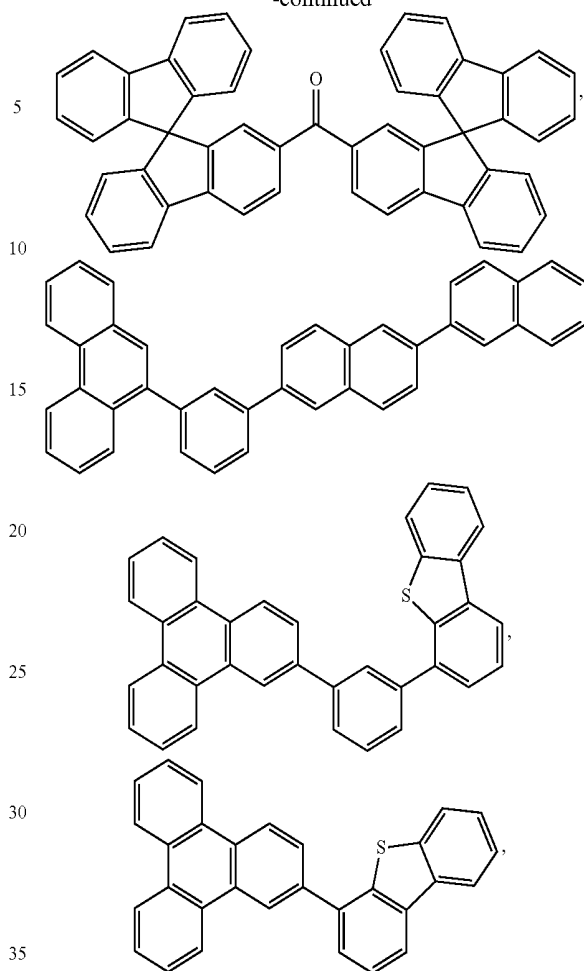

and combinations thereof.

31. The first device of claim 27, wherein the host material comprises a metal complex.

32. A method for making an organic electronic device, comprising:

providing a first electrode disposed on a substrate;

forming a first organic layer over the first electrode, wherein the first organic layer comprises a first compound; and

forming a second electrode disposed over the first organic layer, wherein the first compound comprises the formula

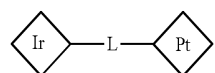

wherein



represents an Ir moiety;

wherein



represents a Pt moiety;

wherein L represents an organic moiety; wherein the formula comprises a first Ir moiety that is an Ir(III) six-coordinated structure;

171

wherein the formula comprises a first Pt moiety that is a Pt(II) four-coordinated structure; and wherein the first Pt moiety comprises a Pt tetradentate structure.

33. The method of claim 32, wherein forming the first organic layer comprises depositing the first compound by solution processing.

34. The method of claim 32, further comprising forming a second organic layer over the first electrode such that the second organic layer is disposed between the first organic layer and the first electrode.

35. The method of claim 34, wherein forming the second organic layer comprises depositing by solution processing.

36. The method of claim 34, wherein the second organic layer comprises a hole injection material.

37. The method of claim 35, further comprising cross-linking the second organic layer.

38. The method of claim 34, further comprising forming a third organic layer over the second organic layer such that the third organic layer is disposed between the second

172

organic layer and the first organic layer, wherein the third organic layer comprises a hole transport material.

39. The method of claim 38, wherein forming the third organic layer comprises depositing by solution processing.

40. The method of claim 39, further comprising cross-linking the third organic layer.

41. The method of claim 38, further comprising depositing a fourth organic layer over the first organic layer such that the fourth organic layer is disposed between the first organic layer and the cathode, wherein the fourth organic layer comprises an electron transport material.

42. The method of claim 41, wherein the fourth organic layer is deposited by vacuum thermal evaporation.

43. The method of claim 41, further comprising depositing a fifth organic layer over the fourth organic layer such that the fifth organic layer is disposed between the fourth organic layer and the cathode, wherein the fifth organic layer comprises an electron transport material.

\* \* \* \* \*

专利名称(译)	有机电致发光材料和器件		
公开(公告)号	<a href="#">US9735378</a>	公开(公告)日	2017-08-15
申请号	US14/021274	申请日	2013-09-09
[标]申请(专利权)人(译)	环球展览公司		
申请(专利权)人(译)	通用显示器公司		
当前申请(专利权)人(译)	通用显示器公司		
[标]发明人	XIA CHUANJUN LIN CHUN		
发明人	XIA, CHUANJUN LIN, CHUN		
IPC分类号	H01L51/00 C07F15/00 C09K11/06 H01L51/50		
CPC分类号	H01L51/009 C07F15/0033 C07F15/0086 C09K11/06 C09K2211/185 H01L51/0085 H01L51/0087 H01L51/5016		
代理机构(译)	DUANE MORRIS LLP		
其他公开文献	US20150069334A1		
外部链接	<a href="#">Espacenet</a> <a href="#">USPTO</a>		

摘要(译)

描述了Ir / Pt金属络合物，含有Ir / Pt金属络合物的器件，以及制造这种器件的方法。Ir / Pt金属络合物包括第一Ir部分和第一Pt部分。第一Ir部分可以是Ir ( III ) 六配位结构。第一Pt部分可以是Pt ( II ) 四配位四齿结构。器件可以具有包括Ir / Pt金属络合物的层。含有Ir / Pt金属配合物的层可以通过溶液法制备。

